



# South African Maritime Safety Authority

Ref: SM6/5/2/1

Date: 27 August 2015

## Marine Notice No. 17 of 2015

### Passenger Vessel Stability Criteria – Stability Criteria applicable to South African Certificated Passenger Vessels

TO ALL PRINCIPAL OFFICERS, SURVEY STAFF, NAVAL ARCHITECTS, SHIP AND BOAT BUILDERS, SHIP AND BOAT OWNERS, AUTHORISED AGENTS, SAFETY OFFICERS, AND OTHER INTERESTED AND AFFECTED PARTIES

*Marine Notice No 40 of 2013 is cancelled*

#### Summary

The following marine notice details intact and damaged stability requirements and criteria to be applied to South African certificated passenger vessels.

“Passenger vessel” a vessel that carries more than 12 passengers.

“Passenger” any person carried on a vessel, except persons employed as crew, rescued survivors and infants under one year of age.

**Note:** The definition of passenger is not limited to commercial enterprise operations but includes persons proceeding on an excursion for any purpose, who do not form part of the vessel crew.

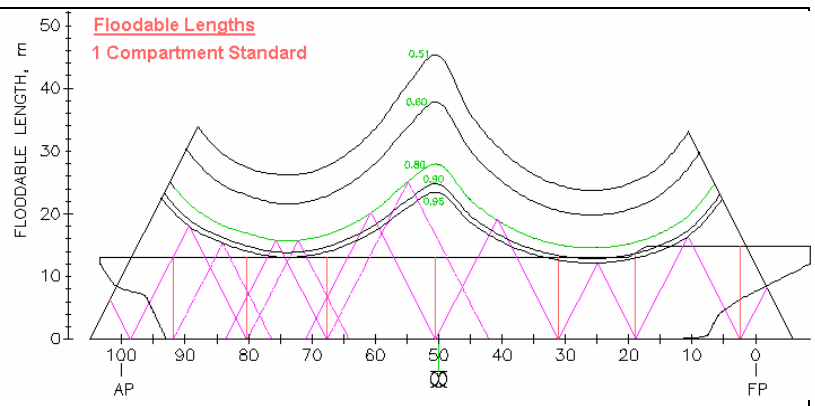
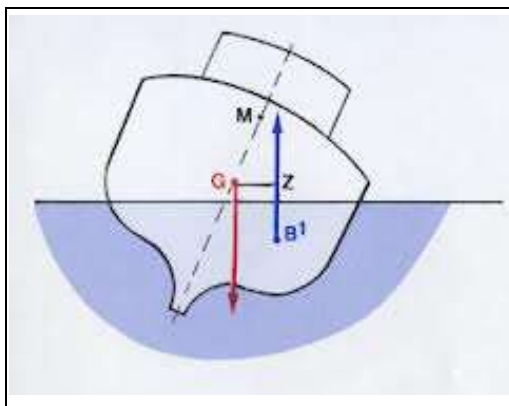

27 August 2015

SM6/5/2/1

Issued by and obtainable from:  
**The South African Maritime Safety Authority**  
146 Lunnon Road  
Hillcrest, Pretoria

PO Box 13186  
Hatfield 0028

Tel: +27 12 366 2600  
Fax: +27 12 366 2601  
E-mail: [marinenotices@samsa.org.za](mailto:marinenotices@samsa.org.za)  
Web Site : [www.samsa.org.za](http://www.samsa.org.za)

## CONTENTS PAGE

- 1. INTRODUCTION**
- 2. DEFINITIONS**
- 3. LIST OF ABBREVIATIONS**
- 4. STABILITY CRITERIA - CLASS I, II & IIA PASSENGER VESSELS**
- 5. STABILITY CRITERIA - CLASS V & VI PASSENGER VESSELS**
  - 5.1 Stability Criteria
  - 5.2 Extent of Damage for Application of Damaged Stability Criteria
    - 5.2.1 Longitudinal Extent of Damage (Bottom or Side)
    - 5.2.2 Transverse Extent of Damage
    - 5.2.3 Vertical Extent of Damage
    - 5.2.4 Breadth of Damage – Multi-hulls
  - 5.3 Permeability of Damaged Compartments
- 6. STABILITY CRITERIA - SMALL PASSENGER VESSELS**
  - 6.1 Small passenger vessels carrying a more than 20 passengers if proceeding to sea or more than 30 passengers if operating on sheltered waters
  - 6.2 Small passenger vessels carrying a maximum of 20 passengers if proceeding to sea or carrying a maximum of 30 passengers if operating on sheltered waters
    - 6.2.1 Intact Stability Criteria
    - 6.2.2 Damaged Stability Criteria
  - 6.3 Built-in Buoyancy versus Watertight Sub-division
  - 6.4 Extent of Damage for Application of Damaged Stability Criteria
    - 6.4.1 Longitudinal Extent of Damage (Bottom or Side)
    - 6.4.2 Transverse Extent of Damage
    - 6.4.3 Vertical Extent of Damage
  - 6.5 Permeability of Damaged Compartments
- 7. PASSENGER DISTRIBUTION**
  - 7.1 General
  - 7.2 Passenger Weights and Centres of Gravity
  - 7.3 Stability File Information and Special Stability Instructions
- 8. FORM AND APPROVAL OF STABILITY INFORMATION**
  - 8.1 Class I, II, IIA, V AND VI Passenger vessels and small passenger vessels carrying more than 20 passengers if proceeding to sea or more than 30 passengers if operating on sheltered waters
  - 8.2 Small passenger vessels carrying a maximum of 20 passengers if proceeding to sea or a maximum of 30 passengers if operating on sheltered waters
- 9. CONCLUSION**

## **List of Annexes**

- Annex 1 - Class V & VI Passenger vessels – Intact and Damaged Stability criteria for monohull and multihull craft
- Annex 2 - Small Passenger Vessel Stability Record Form

### **1. INTRODUCTION**

Stability requirements and criteria applicable to South African certificated passenger vessels are contained in the Merchant Shipping Act, Act 57 of 1951 as amended, the Safety of Navigation Regulations, 1968, the Construction Regulations, 1968 and Merchant Shipping (National Small Vessel Safety) Regulations, 2007. The criteria are however in some cases dated and also do not address the full spectrum of vessel types utilised as passenger vessels in South African waters.

The following marine notice accordingly details intact and damaged stability requirements criteria to be applied to South African certificated passenger vessels.

### **2. DEFINITIONS**

“Authority” means the South African Maritime Safety Authority

“Bulkhead deck” means the uppermost deck up to which transverse watertight bulkheads are carried;

“Class I Passenger Vessel” A ship engaged on voyages any of which are international voyages other than short international voyages.

“Class II Passenger Vessel” A ship, other than a ship of class I, engaged on voyages any of which are short international voyages.

“Class IIA Passenger Vessel” A ship of 70 feet in length or over, other than a ship of class V or VI, engaged on voyages of any kind other than international voyages.

“Class V Passenger Vessel” A ship of 50 feet in length or over engaged only on voyages to sea in fine weather with not more than 40 persons on board, in the course of which voyages the ship is at no time more than 40 miles from the point of departure nor more than 15 miles from land.

“Class VI Passenger Vessel” Ship which operates at a port or is engaged on voyages to sea with not more than 250 persons on board, in the course of which voyages the ship is at no time more than 15 miles from the point of departure nor more than 5 miles from land.

“Downflooding Point” means any opening in the vessels enclosed volume through which progressive flooding could take place which is not able to be closed water/weathertight. Openings which are normally kept closed to an appropriate standard of water/weathertightness and only opened when required for access or operation of equipment and then closed again are not considered to be downflooding points. Small diameter ( $\phi < 3\text{mm}$ ) compartment vents, found typically on the sealed hulls of pontoon vessels, are not considered to be downflooding points.

“Enclosed volume” is the volume of the vessel, which provides the vessel buoyancy and reserve of buoyancy, and is used for the generation of hydrostatic and cross curve data for which forms the baseline for the evaluation of the vessels stability characteristics against applicable criteria.

“High Speed Code (HSC)” The International Code of Safety for High Speed Craft, 2000. Resolution MSC.97(73) as amended by resolutions MSC.175(79) and MSC.222(82).

“High Speed Craft” is a craft capable of maximum speed, in metres per second (m/s), equal to or exceeding  $3.7 \nabla^{0.1667}$  where;  $\nabla$  = Volume of displacement corresponding to the design waterline [ $\text{m}^3$ ].

“Length” means the overall length of the underwater watertight envelope of the rigid hull, excluding appendages, at or below the design waterline in the displacement mode with no lift or propulsion machinery active.

“Margin line” means a line drawn 75mm below the upper surface of the bulkhead deck at the side of a ship and assumed for determining the floodable length of the ship.

“Monohull craft” means any craft which is not a multihull craft.

“Multihull craft” means a craft which in any normally achievable operating trim or heel angle has a rigid hull structure which penetrates the surface of the water over more than one discrete area. A “pontoon vessel” is a type of multihull craft.

“Passenger vessel” a vessel that carries more than 12 passengers.

“Passenger” any person carried on a vessel, except persons employed as crew, rescued survivors and infants under one year of age.

Note: The definition of passenger is not limited to commercial enterprise operations but includes persons proceeding on an excursion for any purpose, who do not form part of the vessel crew.

"Permeability" of a space, means the percentage of the volume of the space that can be occupied by water;

“Pontoon vessel” (sometimes also referred to as a raft) is a multihull craft consisting of two or more flotation (hull) units to which a deck or decks are attached which persons are able to be supported on. The essential difference between a pontoon boat and a conventional multihull craft is that the deck(s) are not integral to the flotation units and do not contribute significantly to the buoyancy of the boat.

"sheltered waters" means any of the following:

- (a) a tidal lagoon or a tidal river.
- (b) the waters within the breakwaters of any port in the Republic.
- (c) inland waters; and,

“inland waters” means the waters of any dam, lagoon, lake, river or wetlands, which are not tidal waters.

“Short International Voyage” is an international voyage in the course of which a ship is not more than 200 miles from a port or place in which the passengers and crew could be placed in safety. Neither the distance between the last port of call in the country in which the voyage begins and the final port destination nor the return voyage shall exceed 600 miles. The final port of destination is the last port of call in the scheduled voyage at which the ship commences its return voyage in to the country in which the voyage began.

“Small Passenger Vessel” A passenger ship or boat which is subject to the Merchant Shipping (National Small Vessel Safety) Regulations, 2007, which includes:

- a. Passenger vessels less than 25 Gross Register Tons (GT) operating on sheltered waters or proceeding to sea.
- b. All passenger vessels operating on inland waters.

Note: Small Passenger Vessel’s are normally categorised as:

- Category R passenger vessel for vessel’s operating on sheltered waters; or,
- Category D or E passenger vessel for vessel’s proceeding to sea up to 5 miles offshore and not more than 15 miles from a safe haven.

A pleasure vessel (vessel used for sport and recreation) may however also become a passenger vessel if more than 12 passengers are carried at any time.

### 3. LIST OF ABBREVIATIONS

SOLAS -	Convention for Safety of Life at Sea
MSA -	Merchant Shipping Act, Act 57 of 1951 (as amended).
SoN -	Safety of Navigation Regulations, 1968
Con -	Construction Regulations, 1969
NSVR -	Merchant Shipping (National Small Vessel Safety) Regulations, 2007
HSC -	“High Speed Code (HSC)” The International Code of Safety for High Speed Craft, 2000. Resolution MSC.97(73) as amended by resolutions MSC.175(79) and MSC.222(82).
dL -	Longitudinal extent of damage in metres [m].

### 4. STABILITY CRITERIA - CLASS I, II and IIA PASSENGER VESSELS

Intact and damaged stability criteria shall be as contained in the latest edition of the Convention for the Safety of Life at Sea (SOLAS) and any supporting codes eg. the High Speed Code, in force at the time of keel of the vessel being laid or the vessel being at a similar stage of construction.

### 5. STABILITY CRITERIA - CLASS V and CLASS VI PASSENGER VESSELS

#### 5.1 STABILITY CRITERIA

Intact and damaged stability criteria shall be as per criteria contained in Annex 1<sup>1</sup>.

#### 5.2 EXTENT OF DAMAGE FOR APPLICATION OF DAMAGED STABILITY CRITERIA<sup>2</sup>

##### 5.2.1 Longitudinal Extent of Damage (Bottom or Side)

**5.2.1.1 Standard Damage** For all vessels the longitudinal extent of damage, dL, shall be the greater of:

- a. The length of one compartment; or,
- b. The least length of a compartment defined by;
  - i.  $0.75 \nabla^{1/3}$ ; or,
  - ii.  $3\text{m} + 0.225 \nabla^{1/3}$ ; or,
  - iii. 11m.

Vessels shall be required to survive the flooding of any one compartment or more than one compartment in the event that the length defined in paragraph 5.2.1.1.b spans more than one compartment.

The damage length shall be measured from the point at which the design waterline intersects with the bow of the bow and then aft from each watertight bulkhead from forward to aft. At the stern the damaged length shall be measured forward from the point at which the design waterline intersects the stern. The principle is illustrated in the sketch below with the damaged length, dL, indicated by the length of the arrow. In the example, the damaged length crosses the watertight bulkhead forward of the stern meaning that the longitudinal extent of damage for the vessel would include compartment 4 and compartment 5.

---

<sup>1</sup> Derived from HSC

<sup>2</sup> Derived from Con Part 1, Chapter 2 and HSC Chapter 2.6

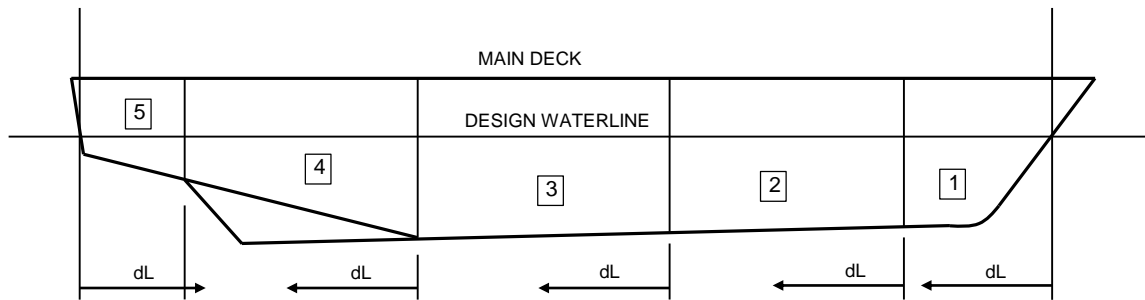

**5.2.1.2 Raking Damage** For high speed vessels raking damage shall additionally be considered as follows:

Any part of the surface of the hull(s) is considered vulnerable to raking damage if:

- It is in contact with the water at 90% of maximum speed in smooth water.
- It also lies below two planes which are perpendicular to the craft centreline plane and at heights shown in the below figure.

For multihulls, individual hulls are considered separately.

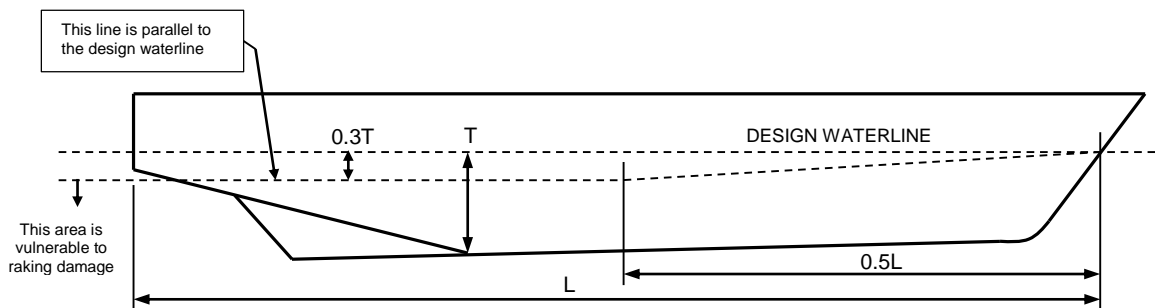

T = Maximum draught of the hull (Each hull considered individually in the case of multihulls) to the design waterline, excluding any non-buoyant structure, provided that structures such as single plate skegs or solid metal appendages shall be considered to be non-buoyant and thus excluded

Two different longitudinal extents shall be considered separately:

- 55% of length, L, measured from the most forward point of the underwater buoyant volume of each hull; and
- a percentage of the length, L, applied anywhere along the length of the craft, equal to 35% for craft where L = 50m and over and equal to (L/2 + 10)% for craft where L < 50m.

**5.2.2 Transverse Extent of Damage**

The standard transverse extent of damage shall be

- $0.2 \nabla^{1/3}$ ; or,
- $0.12 \nabla^{1/3}$  into the main buoyancy hull when the craft is fitted with inflated skirts or non-buoyant side structure.

The extent of damage must be considered to occur at any point on the hull, from the keel to the bulkhead deck, and to penetrate to the transverse extent defined above.

For raking damage the transverse penetration of the damage shall be  $0.04 \nabla^{1/3}$  or 0.5m acting perpendicular to the shell from the bottom plating up the side of the hull as far as the vertical extent defined in the drawing above (paragraph 4.2.1.2).

**5.2.3 Vertical Extent of Damage**

For standard damage the vertical extent of damage shall be taken as the full vertical extent of the buoyant part of the hull defined by the “enclosed volume”.

For raking damage the vertical extent of damage shall be as defined in the sketch in paragraph 4.2.1.2.

#### 5.2.4 Breadth of Damage – Multi-hulls

For multihull craft an obstruction at or below the design waterline of up to 7 metres width shall be considered in determining the number of hulls damaged at any one time ie. single and multiple hull damage must be considered up to a width of 7 metres.

### 5.3 PERMEABILITY OF DAMAGED COMPARTMENTS

5.3.1 General For the purpose of making damaged stability calculations, the permeability of compartments should be taken as follows:

- a. Spaces occupied by cargo or stores – 60%
- b. Spaces occupied by accommodation – 95%
- c. Spaces occupied by machinery – 85%
- d. Spaces occupied by liquids – 0% or 95%, whichever results in the more severe case.
- e. Void spaces – 95%

Notwithstanding the above, compartment permeability determined by direct calculation shall be used when a more onerous condition results and may be used where a less onerous condition results.

5.3.2 Built-in Buoyancy Where approved built-in buoyancy is used to reduce the permeability of a compartment(s), the compartment(s) permeability shall be determined by direct calculation.

## 6. STABILITY CRITERIA - SMALL PASSENGER VESSELS

### 6.1 SMALL PASSENGER VESSELS CARRYING MORE THAN 20 PASSENGERS IF PROCEEDING TO SEA OR MORE THAN 30 PASSENGERS IF OPERATING ON SHELTERED WATERS.

NSVR, Regulation 6, Annex 1, 16(4)

Every passenger vessel certified to carry more than 20 passengers must comply with stability criteria applicable to ships classified as class VI passenger ships in terms of the Safety of Navigation or with sub-item (2) in the case of category R passenger vessels, as decided by the Authority.

The intact and damaged stability criteria shall be **as for class VI passenger vessels** as defined in paragraph 5 and annex 1 for passenger vessels carrying more than 20 persons and “it is decided” by the Authority that the same criteria will apply to category R (sheltered waters) passenger vessels carrying more than 30 passengers.

In cases where Principal Officers are of the opinion that a category R passenger vessel carrying more than 30 passengers may be evaluated using methods and criteria defined in paragraph 6.2 then a specific motivation must be submitted for approval by a SAMSA Regional Manager prior to proceeding in this manner.

### 6.2 SMALL PASSENGER VESSELS CARRYING A MAXIMUM OF 20 PASSENGERS IF PROCEEDING TO SEA OR CARRYING A MAXIMUM OF 30 PASSENGERS IF OPERATING ON SHELTERED WATERS.

#### 6.2.1 Intact Stability Criteria<sup>3</sup>

Compliance with intact stability may be demonstrated theoretically or practically. The following criteria applies:

- a. With the vessel in the worst anticipated intact condition and, as far as is practicable, with 75 per cent of the passengers congregated on one side of the vessel and 25 per cent on the other side, the angle of heel may not exceed seven degrees and may not result in deck-edge immersion of the vessel.

<sup>3</sup> NSVR Regulation 6, Annex 1, 16(2)  
MN 17 of 2015

Deck-edge immersion is defined as follows for the following small vessel types:

- i. Un-decked or Open Vessel The point at which water reaches the margin line.

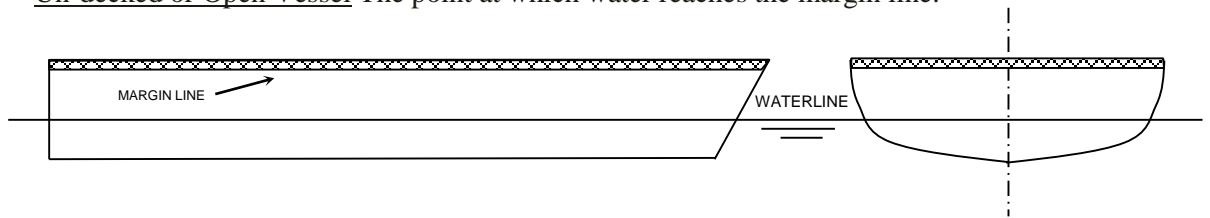

- ii. Decked Vessel The point at which water comes on deck. Where side and or transom scuppers are provided (required in way of solid bulwarks which will create wells for water to accumulate) these scuppers may be provided with non-return arrangements to prevent water coming on deck. (Non-return arrangements provided in way of scuppers are however to be regarded as open for determination of the downflood point(s) and angle(s)).

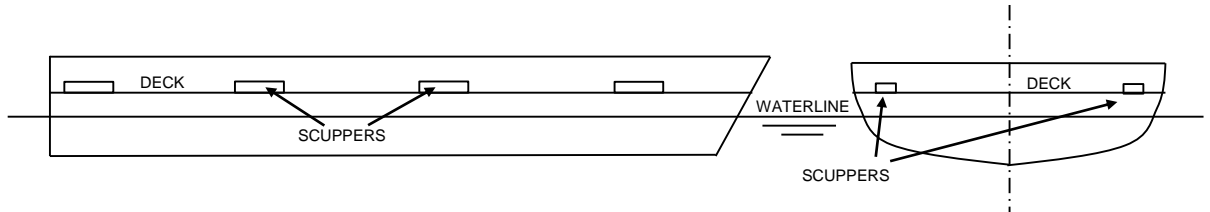

- b. With the vessel in the worst anticipated intact condition and, as far as is practicable, with all of the passengers congregated on one side, neither may a capsizing moment be introduced nor may the resultant angle of heel result in a down-flooding point being reached.

Note: For pontoon vessels, a capsizing moment is regarded as being introduced when, with the vessel in its worst anticipated intact condition and, as far as is practicable, with all of the passengers congregated on one side, neither may 50 per cent of the initially exposed hull volume (Reserve of Buoyancy) be submerged, nor may the resultant angle of heel result in a downflood point being reached. The reserve of buoyancy may not include downflood point(s).

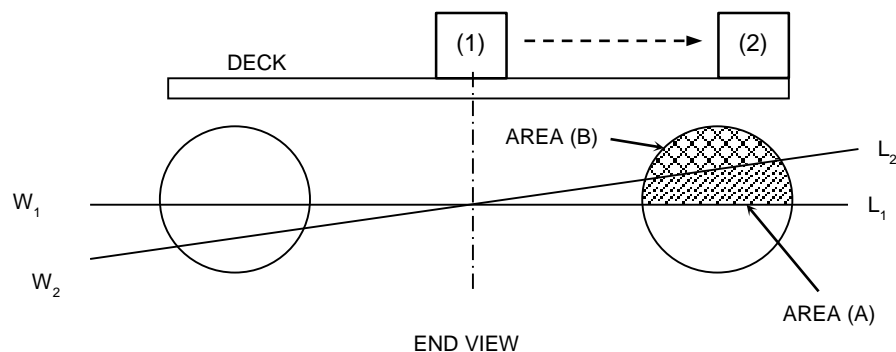

$W_1 L_1$  – FULL LOAD WATERLINE (SYMMETRICAL LOADING)

$W_2 L_2$  – MAXIMUM HEELING MOMENT WATERLINE (PASSENGER CROWDING)

WITH THE PASSENGER LOAD IN THE EXTREME OUTBOARD POSITION;  
AREA (B) MUST BE EQUAL TO OR GREATER THAN AREA (A).

- c. With the vessel in its fully loaded condition including passengers, crew and fuel, the freeboard at the lowest point may not be less than 381 millimetres for vessels not exceeding 6,1 metres in length and 762 millimetres for vessels of 18,3 metres in length; for vessels of intermediate length, the freeboard is to be obtained by linear interpolation. Freeboard is measured as follows for the following vessel types:

- i. Decked or Open Vessel
- ii. Decked Vessel – Scuppers
- iii. Pontoon Vessel

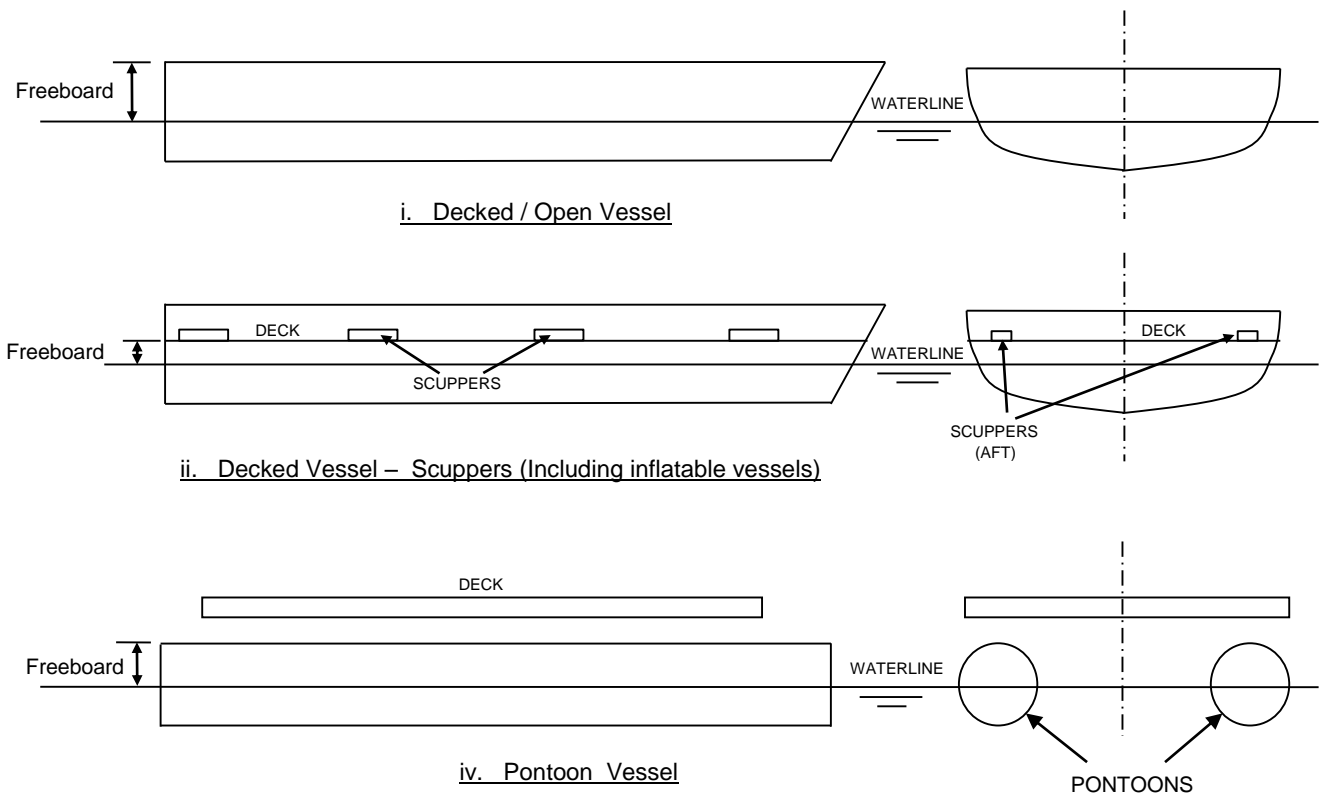

Note: Application of the minimum freeboard criteria applies primarily to vessels provided with watertight sub-division for compliance with applicable criteria. Some latitude may be applied by Principal Officers for vessels provided with built-in buoyancy or a combination of watertight sub-division and built-in buoyancy to achieve compliance provided that compliance with all other criteria is achieved.

d. Longitudinal Stability – Applicable to Pontoon Vessels and Barges only

With the pontoon vessel in its worst anticipated intact condition and, as far as is practicable, with all of the passengers congregated as far forward as possible or as far aft as possible the resultant trim angle shall not result in submersion the top of the pontoon(s) at any location.

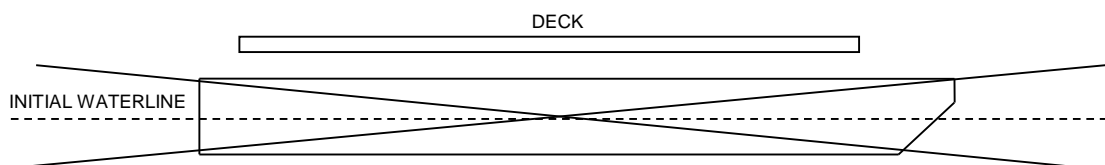

MAXIMUM FORWARD AND AFT TRIMMED WATERLINES AS A RESULT OF PASSENGER CROWDING

### 6.2.2 Damaged Stability Criteria

The vessel must comply with the damaged stability criteria in the vessels worst envisaged load condition including intermediate stages of flooding. Passengers and crew must be considered to be distributed evenly in accordance with the approved seating plan at the time of damage. Compliance with damaged stability criteria may be demonstrated theoretically or practically. The following criteria applies:

- The vessel must remain afloat with positive transverse stability. If confirmed practically, the vessel may not capsize. If confirmed theoretically,  $GM > 0.05$  [m].
- The heel angle as a result of flooding (final and intermediate stages) must be less than 10 [degrees].
- A down flood point(s) may not be reached.

- d. If confirmed theoretically, the maximum righting lever must be greater than 0.05m and range of positive righting lever must be greater than 7 degrees for intermediate stages of flooding.
- e. It must be endeavoured to ensure that the vessel configuration is such that deck-edge immersion does not take place as a result of specified damage. In the event of deck-edge immersion taking place as a risk assessment is required to be carried out to determine the vessel risk resulting from the water on deck with respect to down flood points and potential free surface to the satisfaction of SAMSA.

### **6.3 BUILT-IN BUOYANCY VERSUS WATERTIGHT SUB-DIVISION**

Compliance with damaged stability criteria may normally be achieved through the provision of built-in buoyancy or watertight sub-division or a combination of the two. The NSVR requires however that damaged stability compliance be achieved through the provision of built-in buoyancy only<sup>4</sup>.

Owners/Builders wishing to achieve compliance with damaged stability criteria through the provision of watertight sub-division arrangements or a combination of watertight sub-division and built-in buoyancy are required to apply to SAMSA for an exemption from the built-in buoyancy requirement. The application for exemption must include information on:

- a. Means of inspecting/ascertaining the condition of the sub-divided compartments.
- b. Means of draining or pumping out the sub-divided compartments.
- c. Number of penetrations through the watertight bulkheads, there specific location and proposed means of making the penetrations watertight.

### **6.4 EXTENT OF DAMAGE FOR APPLICATION OF DAMAGED STABILITY CRITERIA**

In cases where watertight sub-division is accepted by SAMSA as an alternative to the provision of built-in buoyancy, the following longitudinal, transverse and vertical extents of damage shall apply.

#### **6.4.1 Longitudinal Extent of Damage (Bottom or Side)<sup>5</sup>**

6.4.1.1 The longitudinal extent of damage shall be the greater of:

- a. The length of one compartment; or,
- b. A length of  $0.8 + 0.1 L$  [m]; where L = Length Overall of the Vessel.

Vessels shall be required to survive the flooding of any one compartment or more than one compartment in the event that the length defined in paragraph 6.4.1.1.b spans more than one compartment.

The damage length shall be measured from the point at which the design waterline intersects with the bow of the bow and then aft from each watertight bulkhead from forward to aft. At the stern the damaged length shall be measured forward from the point at which the design waterline intersects the stern. The principle is illustrated in the sketch below with the damaged length, dL, indicated by the length of the arrow. In the example, the damaged length crosses the watertight bulkhead forward of the stern meaning that the longitudinal extent of damage for the vessel would include compartment 4 and compartment 5.

<sup>4</sup> NSVR Regulation 6, Annex 1(3)

<sup>5</sup> NSVR and SAMSA derivation

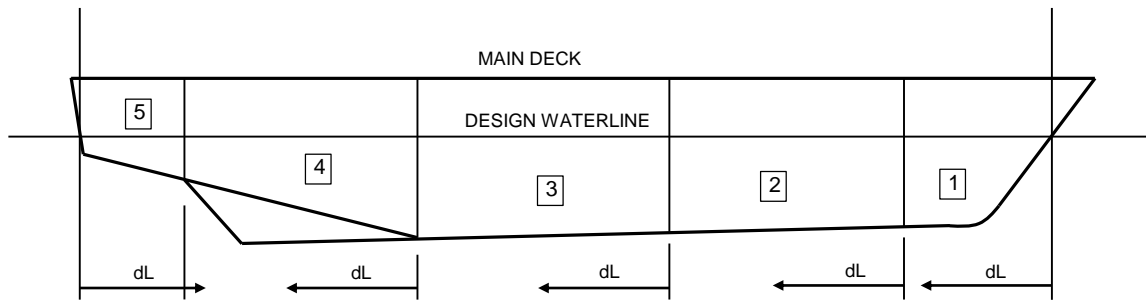

6.4.1.2 In the case of inflatable boats, the longitudinal extent of damage to the inflatable chamber shall be the greater of:

- a. Two adjacent inflatable chambers; or,
- b. A length of  $0.8 + 0.1L$  [m].

In the case of rigid hulled inflatable boats the rigid hull must be considered damaged as per paragraph 6.4.1.1. The longitudinal extent of damage of each hull element (inflatable hull section and rigid hull section) is determined separately but considered to occur simultaneously.

6.4.1.3 **Raking Damage** For high speed vessels raking damage shall additionally be considered as follows:

Any part of the surface of the hull(s) is considered vulnerable to raking damage if:

- a. It is in contact with the water at 90% of maximum speed in smooth water.
- b. It also lies below two planes which are perpendicular to the craft centreline plane and at heights shown in the below figure.

For multihulls, individual hulls are considered separately.

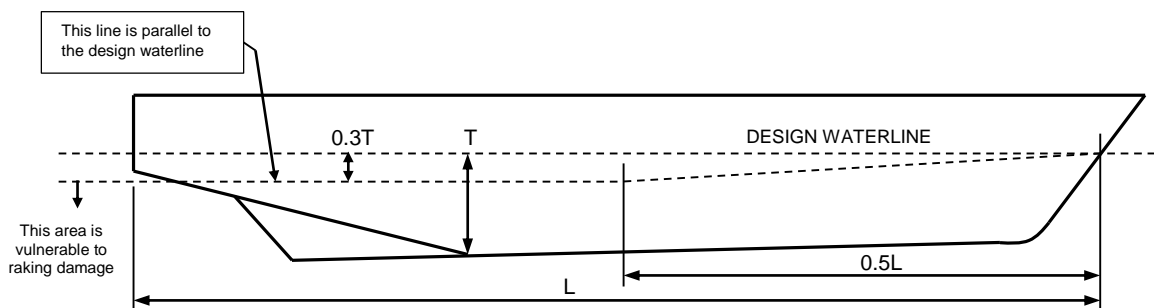

$T =$  Maximum draught of the hull (Each hull considered individually in the case of multihulls) to the design waterline, excluding any non-buoyant structure, provided that structures such as single plate skegs or solid metal appendages shall be considered to be non-buoyant and thus excluded.

Two different longitudinal extents shall be considered separately:

- a. 55% of length,  $L$ , measured from the most forward point of the underwater buoyant volume of each hull; and
- b. a percentage of  $L$ , applied anywhere along the length of the craft equal to  $(L/2 + 10)\%$ .

## 6.4.2 Transverse Extent of Damage

The transverse extent of damage shall be a transverse penetration into the hull of at least 350mm.

In the case of multi-hull or pontoon vessels, damage to one hull only is to be considered, however, if the transverse extent of damage described above results in damage to more than one hull then this damage must also be evaluated.

The extent of damage must be considered to occur at any point on the hull, from the keel to the bulkhead deck, and to penetrate to the transverse extent defined above.

For raking damage the transverse penetration of the damage shall be  $0.04\nabla^{1/3}$  or 0.5m acting perpendicular to the shell from the bottom plating up the side of the hull as far as the vertical extent defined in the drawing above (paragraph 5.4.1.4).

### 6.4.3 Vertical Extent of Damage

For standard damage the vertical extent of damage shall be taken as the full vertical extent of the buoyant part of the hull defined by the “enclosed volume”.

For raking damage the vertical extent of damage shall be as defined in the sketch in paragraph 4.2.1.2.

### 6.4.4 Use of Class V or VI Passenger Vessel Extents of Damage

The extent of damage definitions for class V or VI passenger vessels (Para 5.2) may be used in lieu of the above if requisite information is available.

## 6.5 PERMEABILITY OF DAMAGED COMPARTMENTS

6.5.1 General For the purpose of making damaged stability calculations, the permeability of compartments should be taken as follows:

- a. Spaces occupied by cargo or stores – 60%
- b. Spaces occupied by accommodation – 95%
- c. Spaces occupied by machinery – 85%
- d. Spaces occupied by liquids – 0% or 95%, whichever results in the more severe case.
- e. Void spaces – 95%

Notwithstanding the above, compartment permeability determined by direct calculation shall be used when a more onerous condition results and may be used where a less onerous condition results.

6.5.2 Built-in Buoyancy Where approved built-in buoyancy is used to reduce the permeability of a compartment(s), the compartment(s) permeability shall be determined by direct calculation.

## 7. PASSENGER DISTRIBUTION

### 7.1 General

Every passenger vessel must be provided with seating arrangements, appropriate for the vessel operation and of suitable construction, for every passenger and crew member. The seating plan must be approved by the Authority.

While it is accepted that portable arrangements (eg plastic garden-type chairs or benches) may be suitable for some sheltered water operations, the space provisions on every vessel must at least be in accordance with the below sketch.

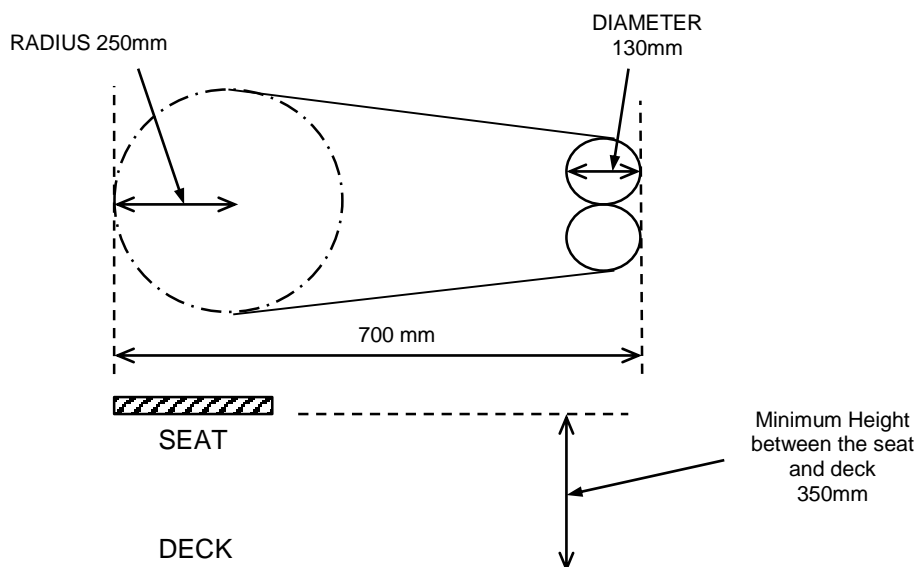

Note: For trailer-borne passenger vessels, the minimum seat width may be reduced to 450mm.

## **7.2 Passenger Weights and Centres of Gravity**

Intact stability criteria for class V, VI, and small passenger vessels requires consideration of vessel heel due to application of a maximum passenger heeling moment. Damaged stability criteria requires that the passengers and crew be considered to be distributed normally in accordance with the approved seating plan at the time of damage.

Where consideration of the effects of a passenger weight, for compliance with intact and damaged stability criteria the following principals shall apply:

- a. Each passenger has a mass of 82.5 kg<sup>6</sup>.
- b. Vertical centre of seated passengers is 0.3 m above the seat.
- c. Vertical centre of standing passengers is 1.0 m above the deck.
- d. The “crowded” distribution of passenger is 4 persons per square metre.
- e. When conducting practical heel testing is carried out, passengers must congregate to one side, as far as is practicable (“crowded” distribution), to create a worst case heeling condition.

## **7.3 Stability File Information and Special Stability Instructions**

Stability files for the above passenger vessels must include drawings/descriptions of the assumed passenger distributions for application of intact and damaged stability criteria. A note must further be included in the “Special Stability Instructions” of the stability file (for reference of the master/skipper) to the effect that a normal passenger distribution is considered for the event of damage and advice should be provided on the use of passengers to counter the vessel list as a result of the damage.

## **8. FORM AND APPROVAL OF STABILITY INFORMATION**

Stability information must be submitted in a form acceptable to the Authority. As a minimum compliance with applicable stability criteria must be shown in the Departure and Arrival load conditions and in any other condition which represents the worst case loading condition(s).

Stability information of all passenger vessels must be approved by SAMSA<sup>7</sup>. The following approaches may be followed:

---

<sup>6</sup> The weight of passengers for existing passenger vessels is to taken as 75 kg. The weight of passengers on passenger vessels constructed or registered after the date of promulgation of this marine notice shall be taken as 82.5 kg.

<sup>7</sup> SoN Regulation 7 and Marine Notice 6 of 2000.

NSVR Regulation 6, Annex 1(16) and this marine notice.

**8.1 CLASS 1, II, IIA, V AND VI PASSENGER VESSELS AND SMALL PASSENGER VESSELS CARRYING MORE THAN 20 PASSENGERS IF PROCEEDING TO SEA OR CARRYING MORE THAN 30 PASSENGERS IF OPERATING ON SHELTERED WATERS.**

For class I, II, IIA, V, VI passenger vessels it is always required that the hull (enclosed volume) of the vessel be modelled in a hydrostatics program for determination of stability curves. The inclining experiment is in all cases carried out by an external naval architect and the subsequently generated stability information is submitted to SAMSA for approval as described in the below flow chart.

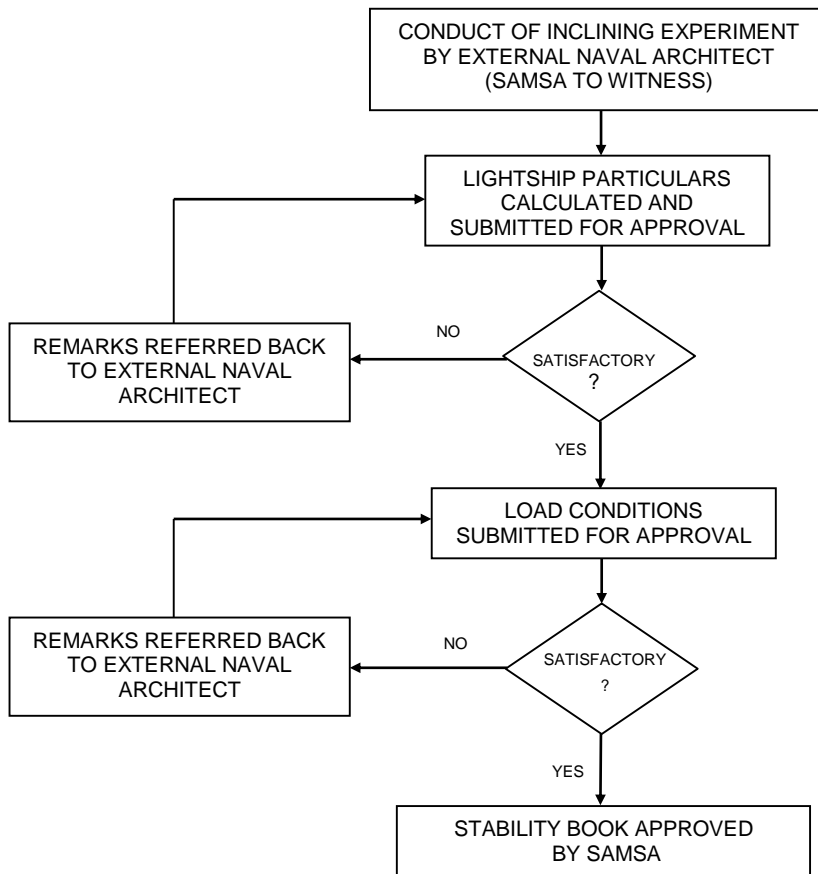

In some cases, the calculation of lightship particulars and load conditions is combined by the external naval architect and then submitted to SAMSA for review.

**8.2 SMALL PASSENGER VESSELS CARRYING A MAXIMUM OF 20 PASSENGERS IF PROCEEDING TO SEA OR CARRYING A MAXIMUM OF 30 PASSENGERS IF OPERATING ON SHELTERED WATERS.**

The NSVR provides that compliance with stability criteria (intact and damaged stability) may be confirmed theoretically or practically. Where stability compliance is confirmed practically, the testing is witnessed and recorded by a SAMSA surveyor using a “Small Passenger Vessel Stability Record” form (See Annex 2). The following flow chart illustrates the processes which may be followed to achieve SAMSA approval of stability information.

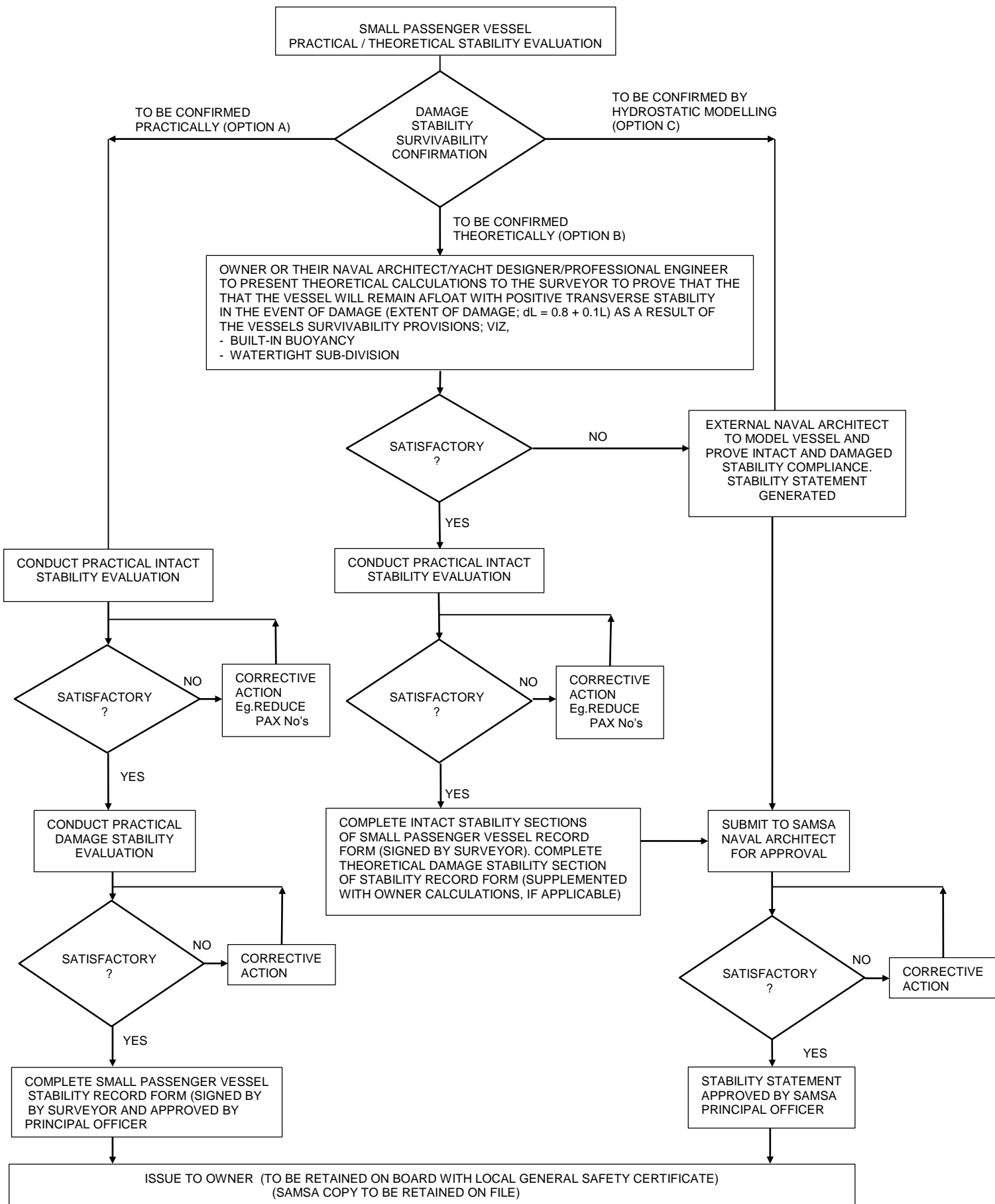

**Remarks:**

(1) **OPTION A** Where the small passenger vessel intact and damaged stability is confirmed practically, the practical confirmation is carried out by the owner and witnessed by a SAMSA surveyor. The following principles apply for practical stability testing. It is the owner/owner representatives responsibility to prepare the vessel and conduct the heeling tests (The role of the SAMSA surveyor is to provide guidance, witness

the practical testing and to record and evaluate the results). SAMSA will provide guidance to owners for the conduct of the practical tests.

- (2) **OPTION B** In some cases the vessels construction is such that theoretical damage evaluation can be carried out without recourse to a hydrostatics program with owners/owners representatives able to confirm compliance with statutory criteria using Archimedes principle and basic geometry calculations. This approach has limitations, however, and;
- a. is not accepted by SAMSA to evaluate a vessels intact stability characteristics.
  - b. will only be accepted by SAMSA to evaluate a vessels damaged stability characteristics:
    - i. For vessel's provided with built-in buoyancy in the hull, evenly distributed below deck (to avoid trim effects in the event of flooding), where it can be shown that a vessel is provided with additional built-in buoyancy equal to at least 100% of the vessel weight in its worst case loaded condition.
    - ii. For multihull or pontoon vessels, with simple hull geometry's, provided with watertight sub-division where it can be shown that the remaining buoyancy in a damaged pontoon is sufficient to ensure that the vessel remains afloat with positive transverse stability.
    - ie. The vessel may not capsize.

For this option the intact stability characteristics are confirmed practically with a SAMSA surveyor witnessing the tests and the theoretical damaged stability evaluation must be submitted to a SAMSA Naval Architect for approval.

- (3) **OPTION C** In the majority of cases, the theoretical approval process will be as for a class I, II, IIA, V or VI passenger vessel, however in some cases where a small passenger vessel may have a large metacentric height eg multihull vessel, pontoon vessel or a barge, SAMSA may exempt owners from the requirement of an inclining experiment provided that:
- (a) The vessel weight is accurately determined (by calculation, weighing or draught survey) and the centres of gravity theoretically calculated with application of a satisfactory safety margin (at least 10% on vertical centre of gravity)
  - (b) A stability prognosis is submitted to SAMSA as part of the application for the exemption.
  - (c) A draught survey is carried out on the vessel to confirm the displacement and longitudinal and transverse centre of gravity calculations submitted to SAMSA.
- (4) In all cases passenger vessels are required to be provided with approved stability information for their operation for the reference of the master/skipper.

## 9. CONCLUSION

This marine notice details intact and damaged stability criteria to be applied to South African registered or licenced passenger vessels and may be reviewed from time to time.

SAMSA should be contacted if clarification or interpretation of criteria applicable to passenger vessels addressed in this marine notice is required.

## ANNEX 1

### CLASS V & VI PASSENGER VESSELS

#### INTACT AND DAMAGED STABILITY CRITERIA FOR MONOHULL AND MULTIHULL CRAFT

The intact and damaged stability criteria shall be applied to monohull and multihull craft as follows:

GM <sub>T</sub>	Angle of Maximum GZ	
	≤ 25°	> 25°
≤ 3 m	Monohull (A) or Multihull (B) Criteria	Monohull (A) Criteria only
> 3 m	Multihull(B) Criteria only	Monohull (A) or Multihull (B) Criteria

#### STABILITY CRITERIA FOR MONOHULL CRAFT (A)

##### 1 Stability criteria in the intact condition

###### 1.1 General Criteria

1.1.1 The area under the righting lever curve (GZ curve) shall not be less than 0.07 m.rad up to  $\Theta = 15^\circ$  when the maximum righting lever (GZ) occurs at  $\Theta = 15^\circ$ , and 0.055 m.rad up to  $\Theta = 30^\circ$  when the maximum righting lever occurs at  $\Theta = 30^\circ$  or above. Where the maximum righting lever occurs at angles of between  $\Theta = 15^\circ$  and  $\Theta = 30^\circ$ , the corresponding area under the righting lever curve shall be:

$$A = 0.055 + 0.001 (30^\circ - \Theta_{\max}) \text{ (m.rad)}$$

where:  $\Theta_{\max}$  is the angle of heel, in degrees, at which the righting lever curve reaches its maximum.

1.1.2 The area under the righting lever curve between  $\Theta = 30^\circ$  and  $\Theta = 40^\circ$  or between  $\Theta = 30^\circ$  and the angle of flooding  $\Theta_F$ , if this angle is less than  $40^\circ$ , shall not be less than 0.03 m.rad.

1.1.3 The righting lever GZ shall be at least 0.2 m at an angle of heel equal to or greater than  $30^\circ$ .

1.1.4 The maximum righting lever shall occur at an angle of heel not less than  $15^\circ$ .

1.1.5 The initial metacentric height GM<sub>T</sub> shall not be less than 0.15 m.

###### 1.2 Weather Criterion

The weather criterion contained in the Intact Stability Code shall apply. In applying the weather criterion the values of wind pressure, P, shall be taken as per the below table<sup>8</sup>:

h (m)	1	2	3	4	5	6 and over
P (Pa)	316	386	429	460	485	504

Where h is the vertical distance of the centre of the projected vertical area of the ship above the waterline, to the waterline.

In determining the value of the wind pressure to be applied, the calculated value of h shall be rounded up to the nearest metre eg. If the calculated value of h = 2.15m, then use; h= 3m and P = 429 Pa.

The angle of heel due to wind shall not exceed  $16^\circ$  or 80% of the angle of deck-edge immersion (whichever is less). In applying the weather criterion account shall also be taken of the roll damping characteristics of individual craft in assessing the assumed roll angle  $\Theta_1$ . Hulls with features which greatly increase damping, such as immersed sidehulls, substantial arrays of foils, or flexible skirts or seals, are likely to experience significantly smaller magnitudes of roll angle. For such craft, therefore, the roll angle shall be derived from model or full-scale tests or in the absence of such data shall be taken as  $15^\circ$ .

### 1.3 Maximum Passenger Heeling

With the vessel in the worst anticipated intact condition and, as far as is practicable, with all of the passengers congregated on one side (See paragraph 7.2 of this marine notice for crowding distribution and centres of gravity), the resultant heel angle shall not exceed 10°.

### 1.4 High Speed Turning

In addition for passenger ships, the angle of heel on account of turning should not exceed 10° when calculated using the following formula:

$$M_R = 0.196 \times V_o^2 \times \Delta \times (KG - d/2)/L$$

where:

- $M_R$  = heeling moment in kNm,
- $V_o$  = service speed in m/s,
- $L$  = length of ship at waterline in m,
- $\Delta$  = displacement in tonnes,
- $d$  = mean draught in m,
- $KG$  = height of centre of gravity above baseline in m

## 2 Criteria for residual stability after damage

2.1 The stability required in the final condition after damage, and after equalization where provided, shall be determined as specified in 2.1.1 to 2.1.4.

2.1.1 The positive residual righting lever curve shall have a minimum range of 0.015 m.rad beyond the angle of equilibrium. This range may be reduced to a minimum of 15°, in the case where the area under the righting lever curve is that specified in 2.1.2, increased by the ratio:

$$15/\text{range}$$

where the range is expressed in degrees. The range shall be taken as the difference between the equilibrium heel angle at which the residual righting lever subsequently becomes negative or the angle at which progressive flooding occurs, whichever is less.

2.1.2 The area under the righting lever curve shall be at least 0.015 m.rad, measured from the angle of equilibrium to the lesser of:

- .1 the angle at which progressive flooding occurs; and
- .2 27° measured from the upright.

2.1.3 A residual righting lever shall be obtained within the range of positive stability, taking into account the heeling moment due to a wind pressure,  $P = 120$  Pa, as calculated by the formula:

$$GZ = (\text{Heeling mom.} / \text{disp.}) + 0.04m$$

$$\text{Where; Heeling moment} = \frac{PAh}{9800}$$

$A$  = the projected lateral area of the ship above the waterline corresponding to the intact condition.

$h$  = vertical distance of the centre of the projected vertical area of the ship above the waterline, to the waterline.

However, in no case shall the righting lever be less than 0.1 m.

The resultant angle of heel as a result of damage and beam wind pressure shall not exceed 10°.

2.2 In intermediate stages of flooding, the maximum righting lever shall be at least 0.05m and the range of positive righting levers shall be at least 7°. In all cases, only one breach in the hull and only one free surface need be assumed.

## **STABILITY CRITERIA FOR MULTIHULL CRAFT (B)**

### **1 Stability criteria in the intact condition**

A multihull craft, in the intact condition, shall have sufficient stability when rolling in a seaway to successfully withstand the effect of either passenger crowding or high-speed turning as described in paragraph 1.4. The craft's stability shall be considered to be sufficient provided compliance with this paragraph is achieved.

#### **1.1 Area under the GZ curve**

The area ( $A_1$ ) under the GZ curve up to an angle  $\Theta$  shall be at least:

$$A_1 = 0.055 \times 30^\circ/\Theta \text{ (m.rad)}$$

where  $\Theta$  is the least of the following angles:

- .1 the downflooding angle;
- .2 the angle at which the maximum GZ occurs; and
- .3  $30^\circ$

#### **1.2 Maximum GZ**

The maximum GZ value shall occur at an angle of at least  $10^\circ$ .

#### **1.3 Heeling due to wind**

The wind heeling lever shall be assumed constant at all angles of inclination and shall be calculated as follows:

$$HL_1 = \frac{P_i \cdot A \cdot Z}{9800 \Delta} \quad (\text{m})$$
$$HL_2 = 1.5 HL_1 \quad (\text{m}) \quad (\text{see figure 1})$$

Where, the value of wind pressure,  $P_i$  shall be taken as per the below table<sup>9</sup>:

h (m)	1	2	3	4	5	6 and over
P (Pa)	316	386	429	460	485	504

Where h is the vertical distance of the centre of the projected vertical area of the ship above the waterline, to the waterline.

In determining the value of the wind pressure to be applied, the calculated value of h shall be rounded up to the nearest metre eg. If the calculated value of h = 2.15m, then use; h= 3m and P = 429 Pa.

and:  $A$  = projected lateral area of the portion of the craft above the lightest service waterline ( $\text{m}^2$ )  
 $Z$  = vertical distance from the centre of  $A$  to a point one half the lightest service draught (m)  
 $\Delta$  = displacement (t)

#### **1.4 Heeling due to passenger crowding or high-speed turning**

Heeling due to the crowding of passengers on one side of the craft or to high-speed turning, whichever is the greater, shall be applied in combination with the heeling lever due to wind ( $HL_2$ ).

##### **1.4.1 Heeling due to passenger crowding**

When calculating the magnitude of the heel due to passenger crowding, a passenger crowding lever shall be developed using the assumptions stipulated on paragraph 6 of this marine notice.

##### **1.4.2 Heeling due to high-speed turning**

When calculating the magnitude of the heel due to the effects of high-speed turning, a high-speed turning lever shall be developed using either the following formula or an equivalent method specifically developed for the type of craft under consideration, or trials or model test data:

$$TL = \frac{1}{g} \frac{V_o^2}{R} \left( KG - \frac{d}{2} \right) \quad (\text{m})$$

where:  $TL$  = turning lever (m)  $R$  = turning radius (m)  
 $V_0$  = speed of craft in the turn (m/s)  $d$  = mean draught (m)  
 $KG$  = height of vertical centre of gravity above keel (m)  $g$  = acceleration due to gravity

### 1.5 Rolling in waves (figure 1)

The effect of rolling in a seaway upon the craft's stability shall be demonstrated mathematically. In doing so, the residual area under the GZ curve ( $A_2$ ), i.e. beyond the angle of heel  $\Theta_h$ , shall be at least equal to 0.028 m.rad up to the angle of roll  $\Theta_r$ . In the absence of model test or other data  $\Theta_r$  shall be taken as  $15^\circ$  or an angle of  $(\Theta_d - \Theta_h)$ , whichever is less.

In calculating the residual area, the heeling lever used shall be the heeling lever due to wind,  $HL_3$  i.e. In figure 2;  $HL_3 = HL_4$

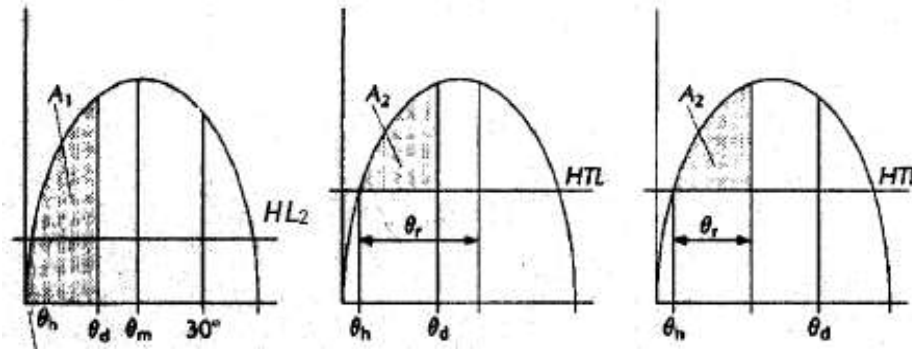

Figure 1 - Intact stability

Abbreviations used in figure 1

- $HL_2$  = Heeling lever due to wind + gusting
- $HTL$  = Heeling lever due to wind + gusting + (passenger crowding or turning)
- $\Theta_m$  = Angle of maximum GZ
- $\Theta_d$  = Angle of downflooding
- $\Theta_r$  = Angle of roll
- $\Theta_e$  = Angle of equilibrium, assuming no wind, passenger crowding or turning effects
- $\Theta_h$  = Angle of heel due to heeling lever  $HL_2$ ,  $HTL$ ,  $HL_3$  or  $HL_4$
- $A_1 \geq$  Area required by 1.1
- $A_2 \geq$  0.028 m.rad

## 2 Criteria for residual stability after damage

2.1 The method of application of criteria to the residual stability curve is similar to that for intact stability except that the craft in the final condition after damage shall be considered to have an adequate standard of residual stability provided:

- .1 the required area  $A_2$  shall be not less than 0.028 m.rad (figure 2 refers); and
- .2 there is no requirement regarding the angle at which the maximum GZ value shall occur.

2.2 The wind heeling lever for application on the residual stability curve shall be assumed constant at all angles of inclination and shall be calculated as follows:

$$HL_3 = \frac{P_d \cdot A \cdot Z}{9800 \Delta}$$

where:

- $P_d = 120$  Pa
- $A$  = projected lateral area of the portion of the ship above the lightest service waterline ( $m^2$ )
- $Z$  = vertical distance from the centre of  $A$  to a point one half of the lightest service draught (m)
- $\Delta$  = displacement (t)

- 2.3 The same values of roll angle shall be used as for the intact stability.
- 2.4 The downflooding point is important and is regarded as terminating the residual stability curve. The area  $A_2$  shall therefore be truncated at the downflooding angle.
- 2.5 The stability of the craft in the final condition after damage shall be examined and shown to satisfy the criteria, when damaged as stipulated in paragraph 4 of this Marine Notice.
- 2.6 In the intermediate stages of flooding, the maximum righting lever shall be at least 0.05 m and the range of positive righting lever shall be at least  $7^\circ$ . In all cases, only one breach in the hull and only one free surface need to be assumed.

### 3 Application of heeling levers

3.1 In applying the heeling levers to the intact and damaged curves, the following shall be considered:

3.1.1 for intact condition:

- .1 wind heeling lever (including gusting effect) ( $HL_2$ ); and
- .2 wind heeling lever (including gusting effect) plus either the passenger crowding or speed turning levers whichever is the greater ( $HTL$ ).

3.1.2 for damage condition:

- .1 wind heeling lever - steady wind ( $HL_3$ ).

### 3.2 Angles of heel due to steady wind

3.2.1 The angle of heel due to a wind gust when the heeling lever  $HL_2$ , obtained as in 1.3, is applied to the intact stability curve shall not exceed  $10^\circ$ .

3.2.2 The angle of heel due to a steady wind when the heeling lever  $HL_3$ , obtained as in 2.2, is applied to the residual stability curve, after damage, shall not exceed  $10^\circ$ .

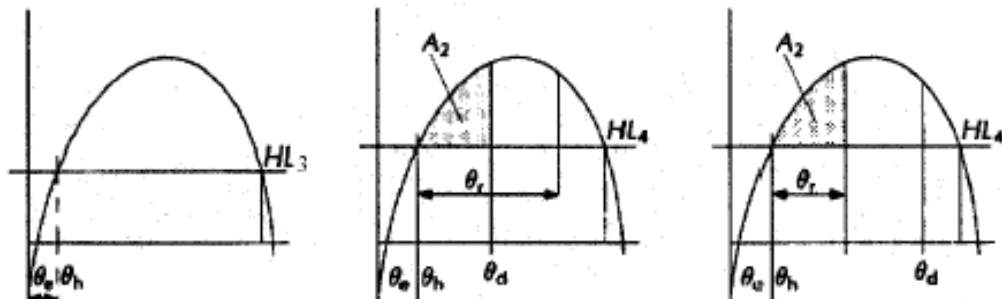

Figure 2 - Damage stability

Abbreviations used in figure 2

$HL_3$  = Heeling lever due to wind =  $HL_4$

$\Theta_m$  = Angle of maximum GZ

$\Theta_d$  = Angle of downflooding

$\Theta_r$  = Angle of roll

$\Theta_e$  = Angle of equilibrium, assuming no wind, passenger crowding or turning effects

$\Theta_h$  = Angle of heel due to heeling lever  $HL_2$ ,  $HTL$ ,  $HL_3$  or  $HL_4$

$A_1 \geq$  Area required by 1.1

$A_2 \geq$  0.028 m.rad

SMALL PASSENGER VESSEL STABILITY RECORD FORM



**SMALL PASSENGER VESSEL  
STABILITY RECORD FORM**

--	--

OFFICIAL NUMBER:	
AREA OF OPERATION:	
MAXIMUM NUMBER OF PERSONS:	
_____	_____
PRINCIPAL OFFICER SIGNATURE	DATE

# PRACTICAL STABILITY TEST

## RESULTS SUMMARY PAGE

### A. INTACT STABILITY

i. Minimum Freeboard (See Page 9)

Required:

Achieved:

PASS

FAIL

ii. Partial Heeling Moment (See Page 10)

Required:

Achieved:

PASS

FAIL

iii. Maximum Transverse Heeling Moment (See Page 10)

Required:  $A2 > A1 - A2$

Achieved:

PASS

FAIL

iv. Maximum Longitudinal Heeling Moment (See Page 12)

Required: Top of Pontoon may not submerge

Achieved:

PASS

FAIL

### B. DAMAGED STABILITY (See Page 14)

Required: Remain Afloat with positive transverse stability

Achieved:

PASS

FAIL

### EXEMPTIONS/REMARKS:

\_\_\_\_\_  
SURVEYOR NAME & SIGNATURE (IF APPLICABLE)

\_\_\_\_\_  
DATE

\_\_\_\_\_  
NAVAL ARCHITECT NAME & SIGNATURE (IF APPLICABLE)

\_\_\_\_\_  
DATE

\_\_\_\_\_  
PRINCIPAL OFFICER SIGNATURE

\_\_\_\_\_  
DATE

## GENERAL INFORMATION

This stability record form is used for recording the results of stability tests and calculations carried out to confirm that small passenger vessels comply with the requirements of the Merchant Shipping (National Small Vessel Safety) Regulations, 2007 (NSVR).

Only SAMSAs officers may carry out surveys of small passenger vessels for the issue of an appropriate Local General Safety Certificate.

When correctly completed and signed by the attending SAMSAs surveyor/NA and approved by the Principal Officer of a port or Proper Officer of an inland region, this stability record form demonstrates the vessels compliance with intact and damaged stability requirements of the NSVR. Complete and approved forms must be retained with the vessels LGSC for reference of the owner and skipper and for presentation at the time of survey and on the vessels file in SAMSAs port offices.

## APPLICATION

This form may only be used for the following small passenger vessel operations:

- a. Category D or E vessel carrying not more than 20 passengers.
- b. Category R vessel carrying not more than 30 passengers.

### Notes:

- No passenger vessel may be operated more than 5 nm from shore and 15 nm from a safe haven.

The following parts of this form **must** be completed:

- a. Monohull - Parts A, B, C, F
- b. Multihull - Parts A, B, D, F
- c. Pontoon Vessel - Parts A, B, E, F
- d. Barges - Parts A, B, C, E7 & F.

NB - Part F relates to the vessels ability to survive reasonable damage ie. Damaged stability characteristics. The vessels intact stability evaluation should not be carried out unless there is a clear understanding of how the vessels damaged stability compliance will be demonstrated (See explanatory flow chart on the next page).

## OPTIONS IN THE EVENT OF NON-COMPLIANCE

1. If the vessel design/configuration does not allow for measurements and evaluation to be carried out in accordance with the instructions contained in each part, the test must be stopped and guidance requested from a SAMSAs Naval Architect before proceeding.
2. The procedures outlined for each part must be followed with all criteria required to be complied with. In the event that criteria are not met, the owner should consider the following options:
  - a. Reduce the number of passengers/other weights until compliance is achieved.
  - b. Stop the test and approach a naval architect or professional engineer to carry out more detailed theoretical calculations or to model the vessel hull and conduct a full stability evaluation.

Note: Surveyors must endeavour to complete required calculations immediately after the conduct of practical testing so that compliance or not may be confirmed and, if necessary, the owner be allowed the option of reducing passenger numbers, for example to achieve compliance, thereby avoiding the inconvenience of having to return to the vessel for further testing at a later date.

**PART A - GENERAL PARTICULARS**

Name of Vessel: Off No.

Owner/Representative: Date:

Contact Tel no. email:

SAMSA Surveyor(s): Weather Conditions

Wind:

Location: Water:

Description of Vessel Operation:

**Application:**

This record form is for the following small passenger vessel operations (Mark the relevant box):

Category D or E vessel carrying not more than 20 passengers.

Category R vessel carrying not more than 30 passengers.

Remarks:

---

---

This record is or the following vessel type (Mark the relevant box):

Monohull - Parts A, B, C & F completed.

Multihull - Parts A, B, D & F completed.

Pontoon Vessel - Parts A, B, E & F completed.

Barge - Parts A, B, C, E7 & F completed.

Remarks:

**PARTS OF THE STABILITY RECORD FORM WHICH ARE NOT RELEVANT TO THE VESSEL TYPE AND OR EVALUATION CARRIED OUT ARE EXCLUDED FROM THIS RECORD.**

## **SKETCH OF ENCLOSED VOLUME AND WATERTIGHT SUB-DIVISIONS**

### Definitions:

- a. Enclosed Volume - The enclosed volume of a vessel is the constructed volume which provides the vessel buoyancy and reserve of buoyancy.
- b. Downflood Point - An opening in the boats hull through which progressive flooding could take place which is not able to be closed watertight (below waterline) or weathertight (Above waterline). Small openings such as small diameter ( $\phi < 3\text{mm}$ ) compartment vents are not considered to be downflood points.
- c. Watertight Sub-divisions - Divisions within the hull structure which prevent flooding from one compartment to another in the event of damage.

A sketch of the vessel in plan and profile view must be provided in the space below clearly identifying the enclosed volume, downflood points and watertight sub-divisions.

**NB -** Owners must ensure that they do not modify the vessel so that the enclosed volume, downflood points and watertight sub-divisions are not negatively affected in any way.

Surveyors must confirm that the enclosed volume, downflood points and watertight sub-divisions are as reflected in the above sketch at the time of vessel inspection.

**PART B – VESSEL PREPARATION AND PREVAILING WEATHER CONDITIONS**

The vessel must be prepared and presented for practical stability evaluation as follows:

Initial Vessel Condition:

- The vessel must be in a complete condition ie. Not still under construction.
- The vessel must upright and moored alongside with slack mooring lines.
- The vessel hull(s) must be confirmed free of water.

Vessel Loaded Condition:

The vessel must be initially loaded with all safety and operational equipment on board, excluding crew and passengers. Fuel and water tanks must be between 75% and 100% full.

Persons or weights may be used to represent the crew and passenger load (Persons/weights must be prepared and ready for use as required by the attending surveyor).

In the event of weights being utilised, each “passenger/crew” shall be represented by a weight of 82.5 kg.

Standing passengers shall be assumed to congregate at 0.25 m<sup>2</sup> per person and their vertical centre of gravity shall be assumed to be 1.0m above the deck.

Seated passengers shall be provided with a minimum seat spacing of 500mm and their vertical centre of gravity shall be assumed to be 0.3m above the seat.

In the event of persons being used as “passengers/crew”, the principles outlined above should be applied when distributing persons in the course of the tests.

Weather Conditions:

The prevailing weather conditions must allow for the required tests to be carried out in a safe and controlled manner and for freeboard measurements to be accurately taken.

Surveyor Confirmation:

The vessel condition and prevailing weather conditions are considered satisfactory for the conduct of the requisite testing.

Remarks:

**PART C – INTACT STABILITY (MONOHULLS)**

**1. Vessel Principal Particulars**

- a. Length Overall; LOA = \_\_\_\_\_ [m]
  - b. Breadth (max); B = \_\_\_\_\_ [m]
  - c. Breadth for measured freeboards at midships; B<sub>F</sub> = \_\_\_\_\_ [m]
- Note: The heel angle (Para 3) is calculated from freeboards measured at this position

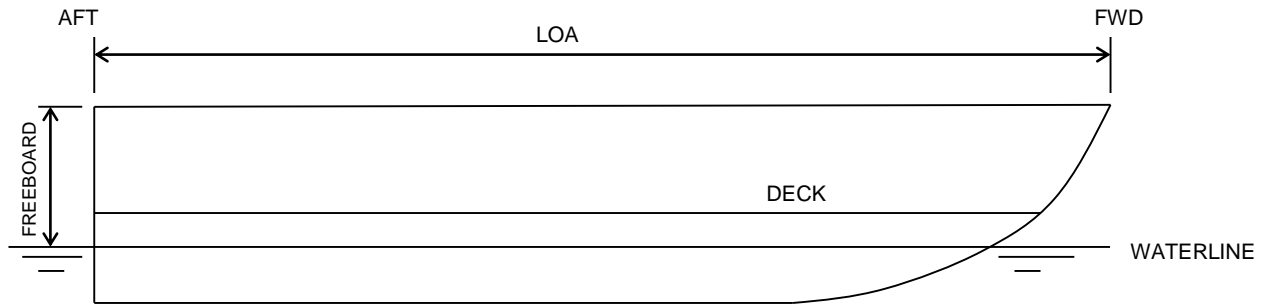

Note: Freeboard on a decked “wet-deck vessel is the distance from the waterline to the lowest point of water ingress on a vessel (excluding scuppers) and may also be in way of the transom. Freeboard on a decked conventional vessel is from the waterline to the deck.

**2. Record of Initial Freeboard Measurements**

Measure the vessel freeboards (forward, midships & aft) with the vessel in the following condition:

- Engine and other solid weights on board.
- Fuel and other tanks 75% to 100% full.
- Crew and Passengers not on board.

Description	Freeboard [mm]		
	Port	Stbd	Mean
Forward			
Midships			
Aft			

Remarks: \_\_\_\_\_

**3. Record of Loaded Freeboard Measurements**

Measure the vessel freeboards (forward, midships & aft) with the vessel in the fully loaded condition; viz,

- Crew and Passengers on board (in addition to loads in paragraph 2).

Description	Freeboard [mm]		
	Port	Stbd	Mean
Forward			
Midships			
Aft			

Remarks: \_\_\_\_\_

**4. Criteria:** Freeboard at lowest point (in fully loaded condition) may not be less than:

$$F_{MIN} = (762 - \left(\frac{18.3 - LOA}{12.2}\right) \times 381)$$

$$= \text{_____ [mm]}$$

PASS	FAIL
------	------

Remarks: \_\_\_\_\_  
 \_\_\_\_\_  
 \_\_\_\_\_

**5. Intact Stability – Maximum Heeling Moment**

Step 1 - With the vessel in an upright fully loaded condition, measure the freeboards at midships, Port and Stbd (Transfer midship values from paragraph 2)

Step 2 - Transfer the weights or “passengers” in a controlled manner from Port to Stbd so that 75% of the passengers are on the Stbd Side and 25% remain on the Port Side. Measure and record the freeboards at midships and calculate the heel angle.

**Criteria:** Heel angle less than 7 degrees and deck edge immersion may not occur.

Heel Angle;  $\theta = \tan^{-1} (\text{Freeboard Port} - \text{Freeboard Stbd})/B_F$

Step 3 - Transfer the remainder of the weights/“passengers” to the Stbd Side so that the maximum practical heeling moment to Stbd is created. Measure and record the freeboards at midships.

**Criteria:** Capsizing moment may not be introduced nor may a downflood point(s) be reached.

Step 4 - Restore the weights/“passenger” to the initial condition (as in Step 1).

Step 5 - Repeat Step 2 but transferring the weights/”passengers” from Stbd to Port.

Step 6 - Repeat Step 2 but transferring the weights/”passengers” from Stbd to Port.

Step 7 - Restore the weights/“passenger” to the initial condition (as in Step 1).

Step	Description	Freeboard Measurement at Midships [mm]		Heel Angle [degrees]	Deck Edge Immersion? Yes/No	Downflood Point reached? Yes/No
		Port	Stbd			
1	Initial Condition					
2	75/25 Heeling Moment (Stbd)					
3	Maximum Heeling Moment					
4	Restore to Initial Condition					
5	75/25 Heeling Moment (Port)					
6	Maximum Heeling Moment					
7	Restore to Initial Condition					

Description of weights/”passenger” shifted to achieve heeling moments with remarks (if any):

\_\_\_\_\_

\_\_\_\_\_

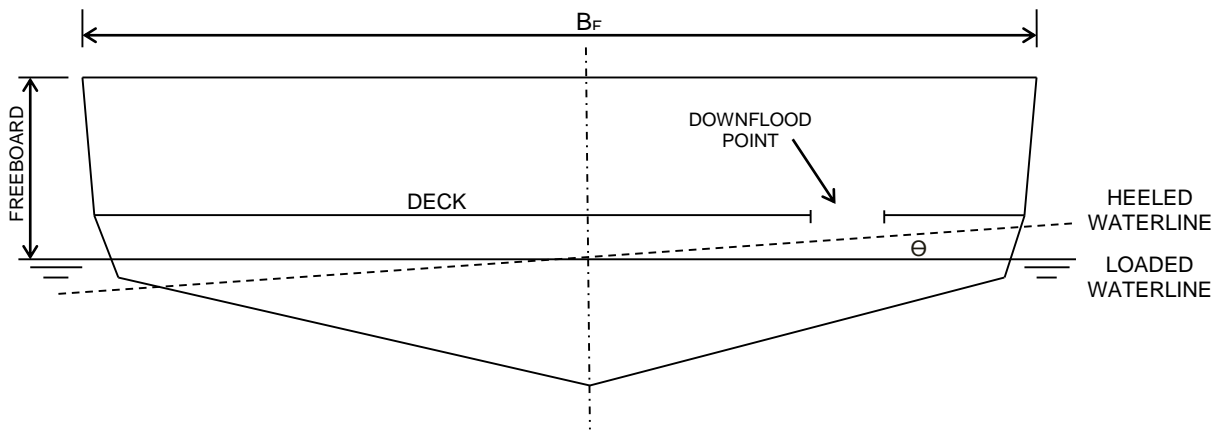

Downflooding point - An opening through which progressive flooding of a hull will take place which is not able to be closed watertight. On decked vessels (see sketch above), downflood points are openings in the hull which lead to below deck space(s). On undecked vessels, the downflood point is the lowest point on the hull which will lead to water ingress into the vessel.

- Criteria:**
- a. For 75/25 applied heeling moment; resultant heel angle less than 7 degrees and no deck edge immersion.
  - b. For maximum applied heeling moment; capsizing moment not introduced and no downflood point reached.

	PASS	FAIL
	PASS	FAIL

Remarks: \_\_\_\_\_

\_\_\_\_\_

**PART D – INTACT STABILITY (MULTIHULLS)**

**1. Vessel Principal Particulars**

- a. Length Overall; LOA = \_\_\_\_\_ [m]
- b. Breadth (max); B = \_\_\_\_\_ [m]
- c. Breadth for measured freeboards at midships; B<sub>F</sub> = \_\_\_\_\_ [m]

Note: The heel angle (Para 3) is calculated from freeboards measured at this position

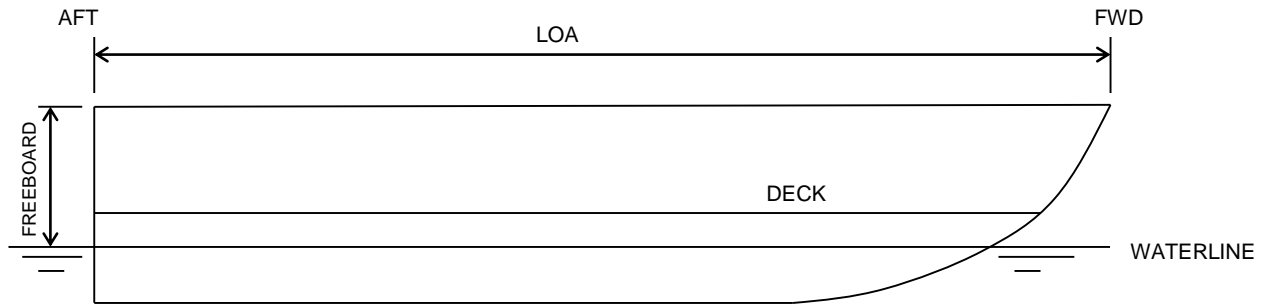

Note: Freeboard on a decked “wet-deck vessel is the distance from the waterline to the lowest point of water ingress on a vessel (excluding scuppers) and may also be in way of the transom. Freeboard on a decked conventional vessel is from the waterline to the deck.

**2. Record of Initial Freeboard Measurements**

Measure the vessel freeboards (forward, midships & aft) with the vessel in the following condition:

- Engine and other solid weights on board.
- Fuel and other tanks 75% to 100% full.
- Crew and Passengers not on board.

Description	Freeboard [mm]		
	Port	Stbd	Mean
Forward			
Midships			
Aft			

Remarks: \_\_\_\_\_

**3. Record of Loaded Freeboard Measurements**

Measure the vessel freeboards (forward, midships & aft) with the vessel in the fully loaded condition; viz,

- Crew and Passengers on board (in addition to loads in paragraph 2).

Description	Freeboard [mm]		
	Port	Stbd	Mean
Forward			
Midships			
Aft			

Remarks: \_\_\_\_\_

**4. Criteria:** Freeboard at lowest point (in fully loaded condition) may not be less than:

$$F_{MIN} = \left( 762 - \left( \frac{18.3 - LOA}{12.2} \right) \times 381 \right)$$

$$= \text{_____ [mm]}$$

PASS	FAIL
------	------

Remarks: \_\_\_\_\_  
 \_\_\_\_\_  
 \_\_\_\_\_

**5. Intact Stability – Maximum Heeling Moment**

Step 1 - With the vessel in an upright fully loaded condition, measure the freeboards at midships, Port and Stbd (Transfer midship values from paragraph 2)

Step 2 - Transfer the weights or “passengers” in a controlled manner from Port to Stbd so that 75% of the passengers are on the Stbd Side and 25% remain on the Port Side. Measure and record the freeboards at midships and calculate the heel angle.

**Criteria:** Heel angle less than 7 degrees and deck edge immersion may not occur.  
 Heel Angle;  $\theta = \tan^{-1} (\text{Freeboard Port} - \text{Freeboard Stbd})/B_F$

Step 3 - Transfer the remainder of the weights/“passengers” to the Stbd Side so that the maximum practical heeling moment to Stbd is created. Measure and record the freeboards at midships.

**Criteria:** Capsizing moment may not be introduced nor may a downflood point(s) be reached.

Step 4 - Restore the weights/“passenger” to the initial condition (as in Step 1).

Step 5 - Repeat Step 2 but transferring the weights/”passengers” from Stbd to Port.

Step 6 - Repeat Step 2 but transferring the weights/”passengers” from Stbd to Port.

Step 7 - Restore the weights/“passenger” to the initial condition (as in Step 1).

Step	Description	Freeboard Measurement at Midships [mm]		Heel Angle [degrees]	Deck Edge Immersion? Yes/No	Downflood Point reached? Yes/No
		Port	Stbd			
1	Initial Condition					
2	75/25 Heeling Moment (Stbd)					
3	Maximum Heeling Moment					
4	Restore to Initial Condition					
5	75/25 Heeling Moment (Port)					
6	Maximum Heeling Moment					
7	Restore to Initial Condition					

Description of weights/”passenger” shifted to achieve heeling moments with remarks (if any):

---



---

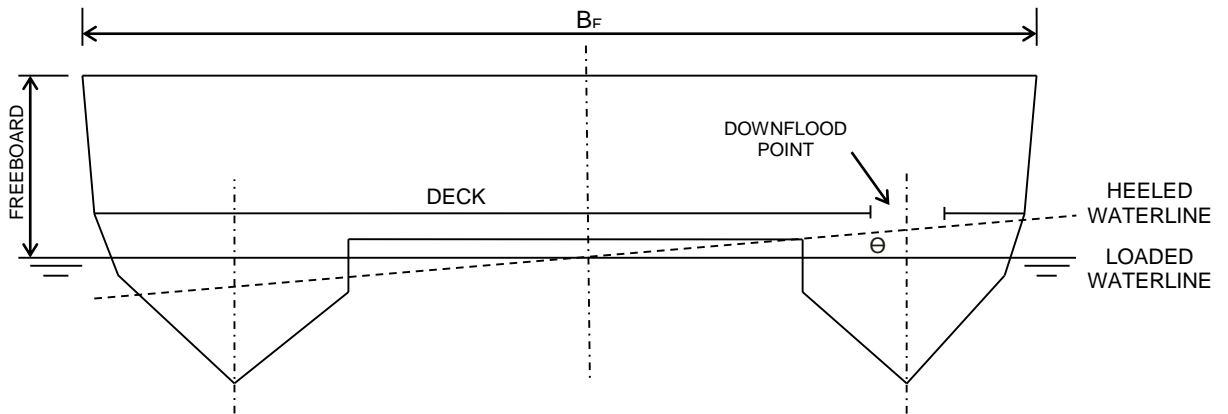

Downflooding point - An opening through which progressive flooding of a hull will take place which is not able to be closed watertight. On decked vessels (see sketch above), downflood points are openings in the hull which lead to below deck space(s). On undecked vessels, the down-flood point is the lowest point on the hull which will lead to water ingress into the vessel.

- Criteria:**
- a. For 75/25 applied heeling moment; resultant heel angle less than 7 degrees and no deck edge immersion.
  - b. For maximum applied heeling moment; capsizing moment not introduced and no downflood point reached.

PASS	FAIL
PASS	FAIL

Remarks: \_\_\_\_\_

\_\_\_\_\_

**PART E – INTACT STABILITY (PONTOON VESSELS)**

**NB – ONLY APPLICABLE TO CATEGORY R VESSELS**

**1. Vessel Principal Particulars**

- a. Length Overall; LOA = [m]
- b. Breadth (max); B = [m]
- c. Breadth for measured freeboards at midships; B<sub>F</sub> = [m]

Note: The vessel heel angles as a result of passenger crowding (Paragraph 3) are calculated from freeboards measured at this position.

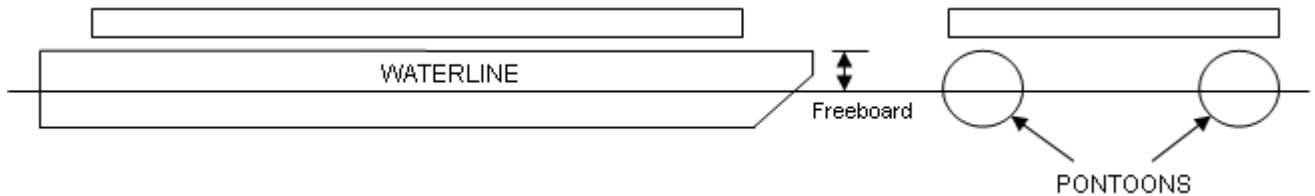

Note: Freeboard is the vertical distance measured from the top of the pontoon to the waterline (Not from the top of the deck).

**2. Record of Initial Freeboard Measurements**

Measure the vessel freeboards (forward, midships & aft) with the vessel in the following condition:

- Engine and other solid weights on board.
- Fuel and other tanks 75% to 100% full.
- Crew and Passengers not on board.

Description	Freeboard [mm]		
	Port	Stbd	Mean
Forward			
Midships			
Aft			

Remarks:

**3. Record of Loaded Freeboard Measurements**

Measure the vessel freeboards (forward, midships & aft) with the vessel in the fully loaded condition; viz,

- Crew and Passengers on board (in addition to loads in paragraph 2).

Description	Freeboard [mm]		
	Port	Stbd	Mean
Forward			
Midships			
Aft			

Remarks:

**4. Criteria:** Freeboard at lowest point (in fully loaded condition) may not be less than:

- L < 6.1 m;                      FB<sub>MIN</sub> = 381 [mm]
- 6.1 m ≤ L ≤ 18.3m;            FB<sub>MIN</sub> =  $(762 - \frac{(18.3-LOA)}{12.2}) \times 381$
- L > 18.3m;                      FB<sub>MIN</sub> = 762 [mm]

PASS	FAIL
------	------

Remarks:

**5. Intact Stability – Maximum Heeling Moment (Transverse Stability)**

Step 1 - With the vessel in an upright fully loaded condition, measure the freeboards at midships, Port and Stbd (Transfer midship values from paragraph 2)

Step 2 - Transfer the weights or “passengers” in a controlled manner from Port to Stbd so that 75% of the passengers are on the Stbd Side and 25% remain on the Port Side. Measure and record the freeboards at midships and calculate the heel angle.

**Criteria:** Heel angle must be less than 7 degrees.

$$\text{Heel Angle; } \gamma = \tan^{-1} (\text{Freeboard Port} - \text{Freeboard Stbd})/B_F$$

Step 3 - Transfer the remainder of the weights/“passengers” to the Stbd Side so that the maximum practical heeling moment to Stbd is created. Measure and record the freeboards at midships.

**Criteria:** A maximum of 50% of the reserve of buoyancy of the Stbd pontoon may become submerged nor may a downflood point(s) be reached.

Step 4 - Restore the weights/“passenger” to the initial condition (as in Step 1).

Step 5 - Repeat Step 2 but transferring the weights/”passengers” from Stbd to Port.

Step 6 - Repeat Step 2 but transferring the weights/”passengers” from Stbd to Port.

Step 7 - Restore the weights/“passenger” to the initial condition (as in Step 1).

Step	Description	Freeboard Measurement at Midships				Heel Angle $\gamma$ [degrees]	Downflood Point reached? Yes/No	$A_2 > (A_1 - A_2)$ ? $A_1 = A_{\text{LOADED}}$ $A_2 = A_{\text{LOADED \& HEELED}}$ Yes/No
		Freeboard mm]		Area's [m <sup>2</sup> ]				
		Port	Stbd	Port	Stbd			
1	Initial Condition							
	75/25 Heeling Moment (Stbd)							
3	Maximum Heeling Moment							
4	Restore to Initial Condition							
5	75/25 Heeling Moment (Port)							
6	Maximum Heeling Moment							
7	Restore to Initial Condition							

Description of weights/”passenger” shifted to achieve heeling moments with remarks (if any):

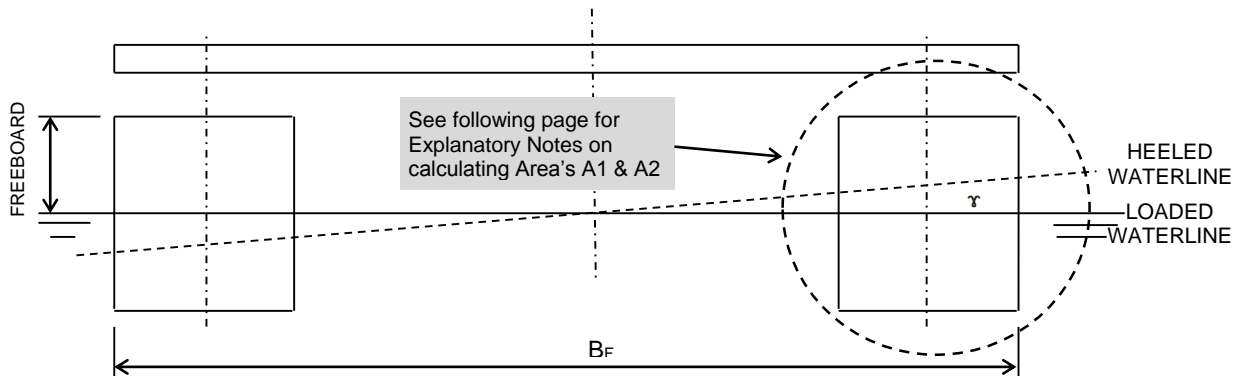

**Downflooding point -** An opening through which progressive flooding of a pontoon will take place which is not able to be closed weathertight.

**Criteria:**

- a. For 75/25 applied heeling moment; Resultant heel angle less than 7 degrees.
- b. For maximum applied heeling moment;  $A_2 > (A_1 - A_2)$  and no downflood point reached.

	PASS	FAIL
	PASS	FAIL

Remarks:

**6. Explanatory Notes – Calculation of Pontoon Area's**

**b. Circular Pontoons**

Step 1 – Measure Pontoon Diameter: D

D = Pontoon Diameter  
r = Pontoon Radius; D/2

Step 2 – With Vessel in “Loaded Condition”

Measure Freeboard: F<sub>1</sub>

F<sub>1</sub> = Loaded Freeboard  
h = F<sub>1</sub> - r

Step 3 - Calculate Area (A<sub>1</sub> + A<sub>2</sub>)

$$\theta = \sin^{-1}(h/r)$$

$$\Theta = 180^\circ - 2\theta \quad (\text{if waterline above half-depth of pontoon})$$

$$\Theta = 180^\circ + 2\theta \quad (\text{if waterline below half-depth of pontoon})$$

$$(A_1 + A_\Delta) = \left(\frac{\theta}{360}\right) \times \pi r^2$$

Step 4 – Calculate Area A<sub>2</sub>

$$A_\Delta = r \cos \theta \times h$$

Step 5 – Calculate Area A<sub>1</sub>

$$A_1 = (A_1 + A_\Delta) - A_\Delta$$

$$= A_{\text{LOADED}}$$

Step 5 – With Vessel in “Loaded & Max. Heeled Condition” Measure Freeboard: F<sub>2</sub>

F<sub>2</sub> = Loaded & Max Heeled Freeboard  
h = F<sub>2</sub> - r

Step 6 – Repeat Steps 3 & 4

NB - For calculation purposes an assumption is made that the “Maximum Heel Loaded Waterline” and “Loaded Waterline” are parallel to each other.

Step 7 – Calculate Area A<sub>1</sub>

$$A_2 = (A_2 + A_\Delta) - A_\Delta$$

$$= A_{\text{LOADED \& HEELED}}$$

Step 8 – Criteria Check

A<sub>LOADED & HEELED</sub> > A<sub>LOADED</sub> - A<sub>LOADED & HEELED</sub>?

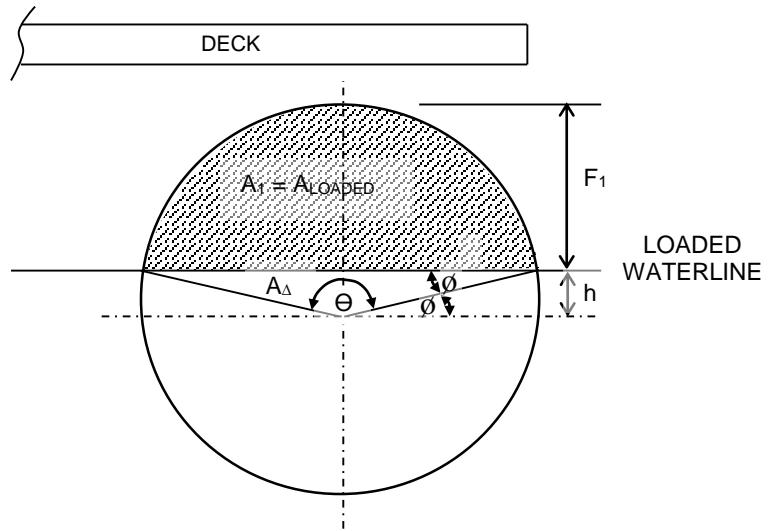

VESSEL IN FULLY LOADED AND CONDITION

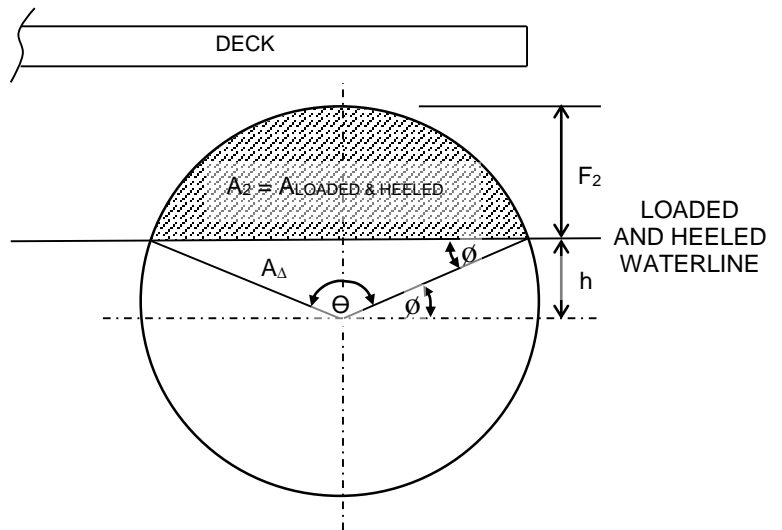

VESSEL IN FULLY LOADED AND MAXIMUM HEELED CONDITION

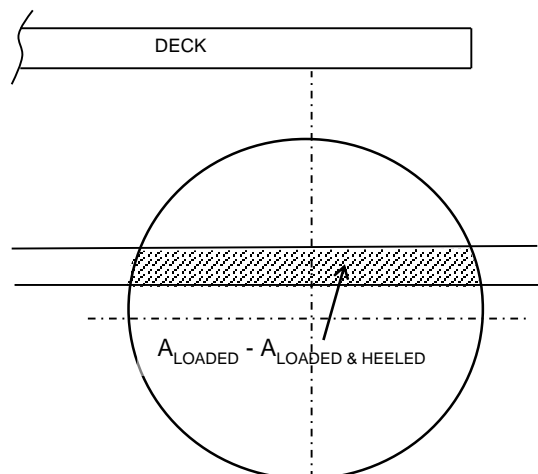
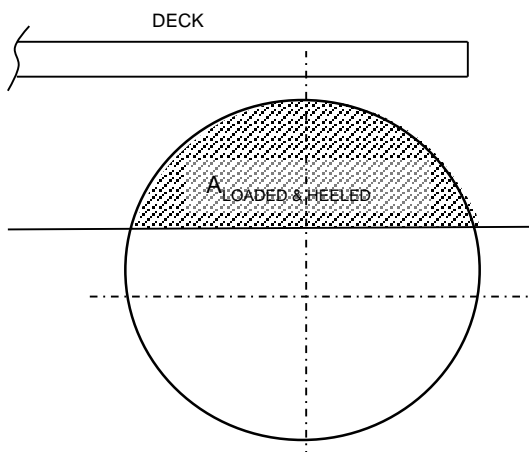

**7. Intact Stability – Maximum Heeling Moment (Longitudinal Stability)**

Step 1 - With the vessel in an upright fully loaded condition, measure the freeboards at midships, Port and Stbd (Transfer midship values from paragraph 2)

Step 2 - Transfer the weights or “passengers” forward in a controlled manner so that the weights or “passengers” are congregated as far forward as is practicable. Measure the trimmed freeboards forward and aft (Port & Stbd)

Step 3 - Restore the weights/“passenger” to the initial condition (as in Step 1).

Step 4 - Repeat Step 2 but transferring the weights/”passengers” aft in a controlled manner so that the weights or “passengers” are congregated as far aft as is practicable. Measure the trimmed freeboards forward and aft (Port & Stbd)

Step 5 - Restore the weights/“passenger” to the initial condition (as in Step 1).

Step	Description	Freeboard Measurements				Forward or Aft section of pontoon(s) submerged? Yes/No
		Freeboard Aft [mm]		Freeboard Fwd [mm]		
		Port	Stbd	Port	Stbd	
1	Initial Condition					
2	Max. Trimming Moment - Fwd					
3	Restore to Initial Condition					
4	Max. Trimming Moment - Aft					
5	Restore to Initial Condition					

Description of weights/”passenger” shifted to achieve trimming moments with remarks (if any):

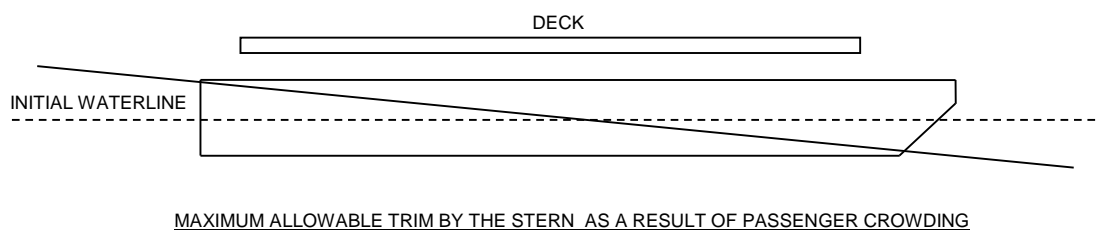
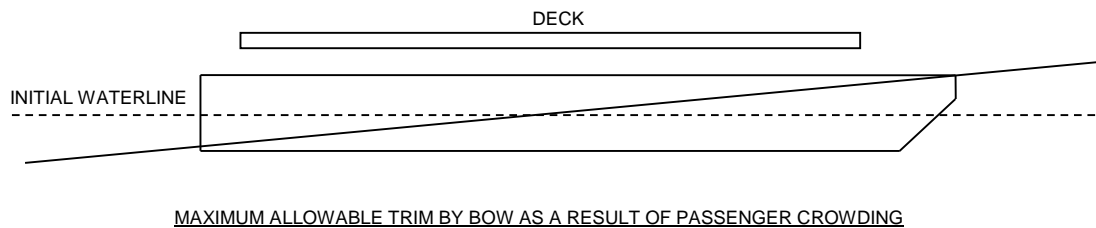

**Criteria:** a. With the vessel trimmed as far forward as is practicable as a result of passenger crowding, the top of the forward pontoon sections may not become submerged.

PASS	FAIL
------	------

b. With the vessel trimmed as far aft as is practicable as a result of passenger crowding, the top of the aft pontoon sections may not become submerged.

PASS	FAIL
------	------

**PART F - DAMAGED STABILITY**

**IMPORTANT**

1. All passenger vessels are required to remain afloat, with positive transverse stability, when damaged ie. Not capsized. All passenger vessels therefore need to demonstrate compliance with this part (practically or theoretically).

a. Vessel method of construction to survive damage (Tick Appropriate Box):

Built-in Buoyancy	
Watertight Sub-division	
Combination of Built-in Buoyancy & Watertight Sub-division	

b. Confirmation of Compliance with Damaged Stability Criteria

Passenger vessels must be able to survive damage as follows:

i. Extent of Damage

Passenger vessels must be able to survive bottom or side damage of length;  $dL = 0.8 + 0.1L$ .

If the compartment lengths are greater than  $0.8 + 0.1L$  then damage of the largest compartment is considered. If the compartment lengths are less than  $0.8 + 0.1L$  then damage of compartments as a result of damage of length;  $dL = 0.8 + 0.1L$  must be considered.

The floodable volume (lost buoyancy) in compartments is therefore dependant on the compartment(s) size and the amount of built-in buoyancy provided in the compartment(s).

ii. Minimum Survival Condition following damage:

Following a damage event with “Extent of Damage” being sustained, the vessel must remain upright with positive transverse stability.

c. Owners have the option of proving compliance theoretically or practically; viz,

i. Theoretical compliance

It must be realised that the ingress of water into a compartment(s) results in changes to the vessel weight and trim and may introduce free surface. Simplified calculations, illustrated in Part F2, may be carried out, however, in the event of doubt and in any case if the water ingress as a result of damage will result in deck edge immersion, is required that a theoretical calculation be carried out by a naval architect and submitted for approval.

ii. Practical Compliance

A practical flooding test of the vessel may be carried out as follows:

Step 1 - The vessel must be initially loaded with all safety and operational equipment on board, including crew and passengers. Fuel and water tanks must be between 75% and 100% full. Crew and passengers must be located as for the vessels normal operation at the start of the test and may not be shifted to improve (or worsen) the condition of the vessel during the practical test.

Step 2 - Determine the “Extent of Damage” for the vessel in accordance with paragraph 1(b)(i) and then progressively flood the vessel, taking care not to create a capsize condition until an equilibrium point is reached where the water level inside the compartment(s) is equal to the outside water level.

Criteria: In the damaged condition, the vessel must remain upright with positive transverse stability.

Part F1 – Practical Compliance

d. Test Results

i. Vessel Initial Loaded Condition

Description	Freeboard [mm]		
	Port	Stbd	Mean
Forward			
Midships			
Aft			

ii. Vessel Damaged Condition

(a) Description of Simulated Damaged Condition

(b) Sketch of Simulated Damaged Condition

(c) Record of Vessel Freeboards in simulated Damaged Condition

Description	Freeboard [mm]		
	Port	Stbd	Mean
Forward			
Midships			
Aft			

e. Criteria: The vessel must remain upright with positive transverse stability.

PASS	FAIL
------	------

No downflood point may be reached.

Remarks: \_\_\_\_\_  
 \_\_\_\_\_  
 \_\_\_\_\_



# SMALL PASSENGER VESSEL STABILITY RECORD FORM

## GENERAL INFORMATION

This stability record form is used for recording the results of stability tests and calculations carried out to confirm that small passenger vessels comply with the requirements of the Merchant Shipping (National Small Vessel Safety) Regulations, 2007 (NSVR).

Only SAMSAs officers may carry out surveys of small passenger vessels for the issue of an appropriate Local General Safety Certificate.

When correctly completed and signed by the attending SAMSAs surveyor and approved by the Principal Officer of the region, this stability record form demonstrates the vessels compliance with intact and damaged stability requirements of the NSVR. Complete and approved forms must be retained with the vessels LGSC for reference of the owner and skipper and for presentation at the time of survey and on the vessels file in SAMSAs port offices.

## APPLICATION

This form may only be used for the following small passenger vessel operations:

- a. Category D or E vessel carrying not more than 20 passengers.
- b. Category R vessel carrying not more than 30 passengers.

### Notes:

- No passenger vessel may be operated more than 5 nm from shore and 15 nm from a safe haven.

The following parts of this form **must** be completed:

- a. Monohull - Parts A, B, C, F
- b. Multihull - Parts A, B, D, F
- c. Pontoon Vessel - Parts A, B, E, F

NB - Part F relates to the vessels ability to survive reasonable damage ie. Damaged stability characteristics. The vessels intact stability evaluation should not be carried out unless there is a clear understanding of how the vessels damaged stability compliance will be demonstrated (See explanatory flow chart on the next page).

## OPTIONS IN THE EVENT OF NON-COMPLIANCE

1. If the vessel design/configuration does not allow for measurements and evaluation to be carried out in accordance with the instructions contained in each part, the test must be stopped and guidance requested from a SAMSAs Naval Architect before proceeding.
2. The procedures outlined for each part must be followed with all criteria required to be complied with. In the event that criteria are not met, the owner should consider the following options:
  - a. Reduce the number of passengers/other weights until compliance is achieved.
  - b. Stop the test and approach a naval architect or professional engineer to carry out more detailed theoretical calculations or to model the vessel hull and conduct a full stability evaluation.

## FLOW CHART FOR STABILITY EVALUATION PROCESS

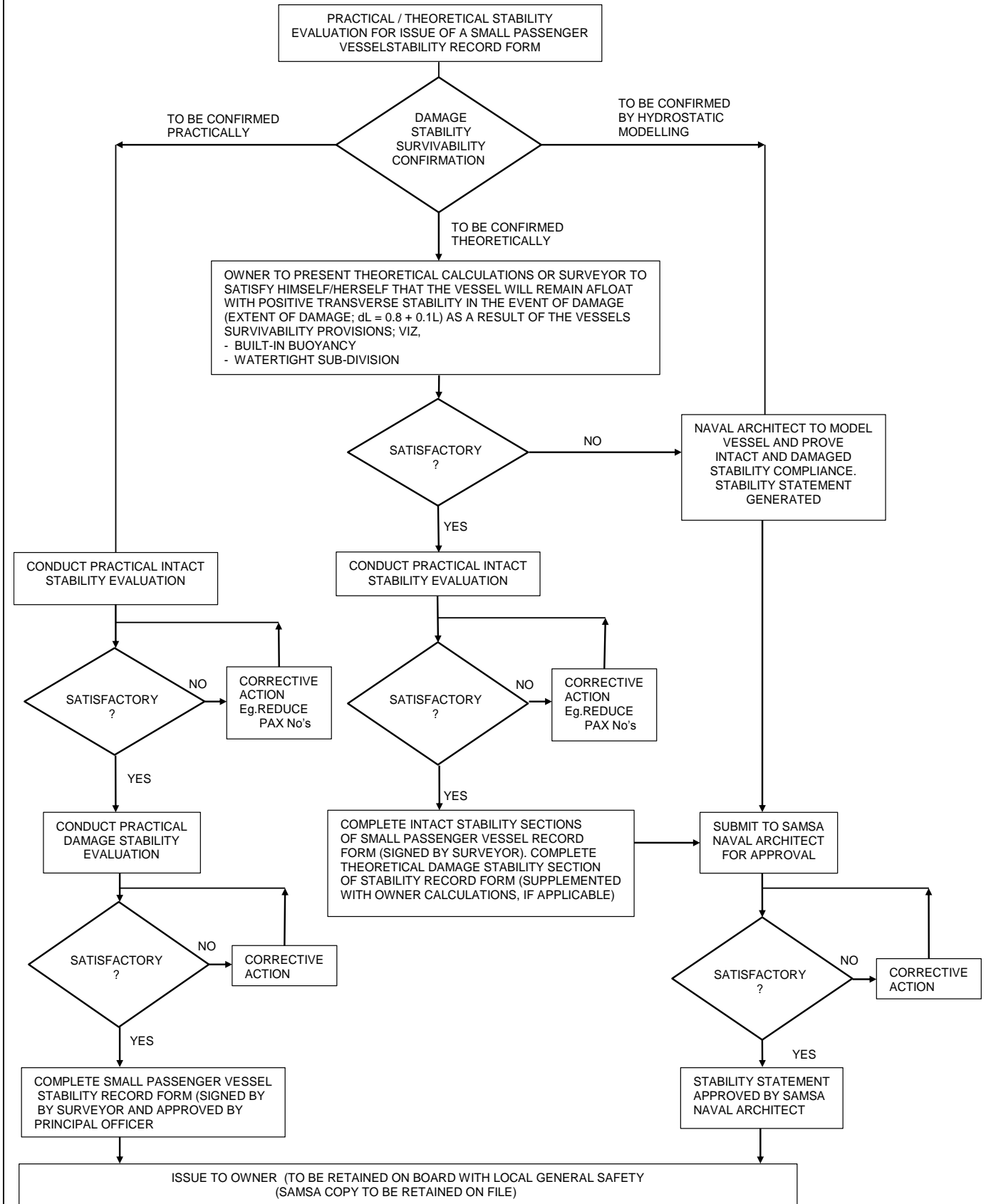

**PART A - GENERAL PARTICULARS**

Name of Vessel: \_\_\_\_\_

Off No. \_\_\_\_\_

Owner/Representative: \_\_\_\_\_

Date: \_\_\_\_\_

SAMSA Surveyor(s): \_\_\_\_\_

\_\_\_\_\_

**Weather Conditions**

Location: \_\_\_\_\_

Wind: \_\_\_\_\_

Water: \_\_\_\_\_

Description of Vessel Operation:

\_\_\_\_\_  
\_\_\_\_\_  
\_\_\_\_\_  
\_\_\_\_\_

**Application:**

This record form is for the following small passenger vessel operations (Mark the relevant box):

Category D or E vessel carrying not more than 20 passengers.

Category R vessel carrying not more than 30 passengers.

This record is or the following vessel type (Mark the relevant box):

Monohull - Parts A, B, C & F completed.

Multihull - Parts A, B, D & F completed.

Pontoon Vessel - Parts A, B, E & F completed.

Surveyor Remarks:

\_\_\_\_\_  
\_\_\_\_\_  
\_\_\_\_\_  
\_\_\_\_\_  
\_\_\_\_\_  
\_\_\_\_\_

**PART B – VESSEL PREPARATION AND PREVAILING WEATHER CONDITIONS**

The vessel must be prepared and presented for practical stability evaluation as follows:

Initial Vessel Condition:

- The vessel must be in a complete condition ie. Not still under construction.
- The vessel must upright and moored alongside with slack mooring lines.
- The vessel hull(s) must be confirmed free of water.

Vessel Loaded Condition:

The vessel must be initially loaded with all safety and operational equipment on board, excluding crew and passengers. Fuel and water tanks must be between 75% and 100% full.

Persons or weights may be used to represent the crew and passenger load (Persons/weights must be prepared and ready for use as required by the attending surveyor).

In the event of weights being utilised, each “passenger/crew” shall be represented by a weight of 82.5 kg.

Standing passengers shall be assumed to congregate at 0.25 m<sup>2</sup> per person and their vertical centre of gravity shall be assumed to be 1.0m above the deck.

Seated passengers shall be provided with a minimum seat spacing of 500mm and their vertical centre of gravity shall be assumed to be 0.3m above the seat.

In the event of persons being used as “passengers/crew”, the principles outlined above should be applied when distributing persons in the course of the tests.

Weather Conditions:

The prevailing weather conditions must allow for the required tests to be carried out in a safe and controlled manner and for freeboard measurements to be accurately taken.

Surveyor Confirmation:

The vessel condition and prevailing weather conditions are considered satisfactory for the conduct of the requisite testing.

Remarks:

---

---

---

---

---

---

---

---

**PART C – INTACT STABILITY (MONOHULLS)**

**1. Vessel Principal Particulars**

- a. Length Overall; LOA = \_\_\_\_\_ [m]
  - b. Breadth (max); B = \_\_\_\_\_ [m]
  - c. Breadth for measured freeboards at midships; B<sub>F</sub> = \_\_\_\_\_ [m]
- Note: The heel angle (Para 3) is calculated from freeboards measured at this position

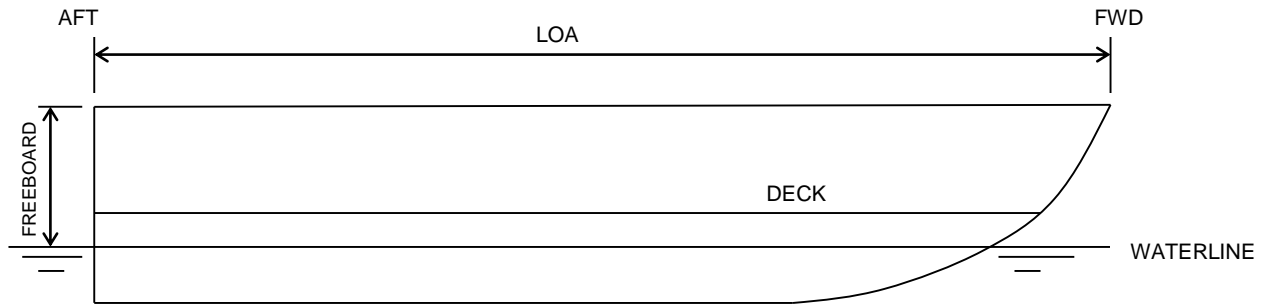

Note: Freeboard on a decked “wet-deck vessel is the distance from the waterline to the lowest point of water ingress on a vessel (excluding scuppers) and may also be in way of the transom. Freeboard on a decked conventional vessel is from the waterline to the deck.

**2. Record of Initial Freeboard Measurements**

Measure the vessel freeboards (forward, midships & aft) with the vessel in the following condition:

- Engine and other solid weights on board.
- Fuel and other tanks 75% to 100% full.
- Crew and Passengers not on board.

Description	Freeboard [mm]		
	Port	Stbd	Mean
Forward			
Midships			
Aft			

Remarks: \_\_\_\_\_

**3. Record of Loaded Freeboard Measurements**

Measure the vessel freeboards (forward, midships & aft) with the vessel in the fully loaded condition; viz,

- Crew and Passengers on board (in addition to loads in paragraph 2).

Description	Freeboard [mm]		
	Port	Stbd	Mean
Forward			
Midships			
Aft			

Remarks: \_\_\_\_\_

**4. Criteria:** Freeboard at lowest point (in fully loaded condition) may not be less than:

$$F_{MIN} = (762 - \left(\frac{18.3-LOA}{12.2}\right) \times 381)$$

$$= \text{_____ [mm]}$$

PASS	FAIL
------	------

Remarks: \_\_\_\_\_  
 \_\_\_\_\_  
 \_\_\_\_\_

**5. Intact Stability – Maximum Heeling Moment**

Step 1 - With the vessel in an upright fully loaded condition, measure the freeboards at midships, Port and Stbd (Transfer midship values from paragraph 2)

Step 2 - Transfer the weights or “passengers” in a controlled manner from Port to Stbd so that 75% of the passengers are on the Stbd Side and 25% remain on the Port Side. Measure and record the freeboards at midships and calculate the heel angle.

**Criteria:** Heel angle less than 7 degrees and deck edge immersion may not occur.  
 Heel Angle;  $\Theta = \tan^{-1} (\text{Freeboard Port} - \text{Freeboard Stbd})/B_F$

Step 3 - Transfer the remainder of the weights/“passengers” to the Stbd Side so that the maximum practical heeling moment to Stbd is created. Measure and record the freeboards at midships.

**Criteria:** Capsizing moment may not be introduced nor may a downflood point(s) be reached.

Step 4 - Restore the weights/“passenger” to the initial condition (as in Step 1).

Step 5 - Repeat Step 2 but transferring the weights/”passengers” from Stbd to Port.

Step 6 - Repeat Step 2 but transferring the weights/”passengers” from Stbd to Port.

Step 7 - Restore the weights/“passenger” to the initial condition (as in Step 1).

Step	Description	Freeboard Measurement at Midships [mm]		Heel Angle [degrees]	Deck Edge Immersion? Yes/No	Downflood Point reached? Yes/No
		Port	Stbd			
1	Initial Condition					
2	75/25 Heeling Moment (Stbd)					
3	Maximum Heeling Moment					
4	Restore to Initial Condition					
5	75/25 Heeling Moment (Port)					
6	Maximum Heeling Moment					
7	Restore to Initial Condition					

Description of weights/”passenger” shifted to achieve heeling moments with remarks (if any):

\_\_\_\_\_

\_\_\_\_\_

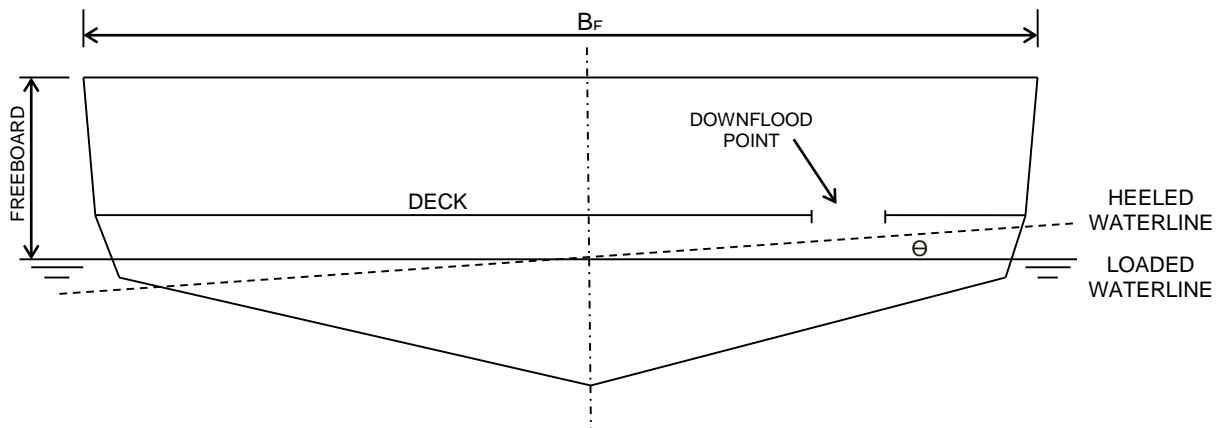

**Downflooding point -** An opening through which progressive flooding of a hull will take place which is not able to be closed watertight. On decked vessels (see sketch above), downflood points are openings in the hull which lead to below deck space(s). On undecked vessels, the down-flood point is the lowest point on the hull which will lead to water ingress into the vessel.

**Criteria:** a. For 75/25 applied heeling moment; resultant heel angle less than 7 degrees and no deck edge immersion.

PASS	FAIL
------	------

b. For maximum applied heeling moment; capsizing moment not introduced and no downflood point reached.

PASS	FAIL
------	------

Remarks:

\_\_\_\_\_

\_\_\_\_\_

**PART D – INTACT STABILITY (MULTIHULLS)**

**1. Vessel Principal Particulars**

- a. Length Overall; LOA = \_\_\_\_\_ [m]
  - b. Breadth (max); B = \_\_\_\_\_ [m]
  - c. Breadth for measured freeboards at midships; B<sub>F</sub> = \_\_\_\_\_ [m]
- Note: The heel angle (Para 3) is calculated from freeboards measured at this position

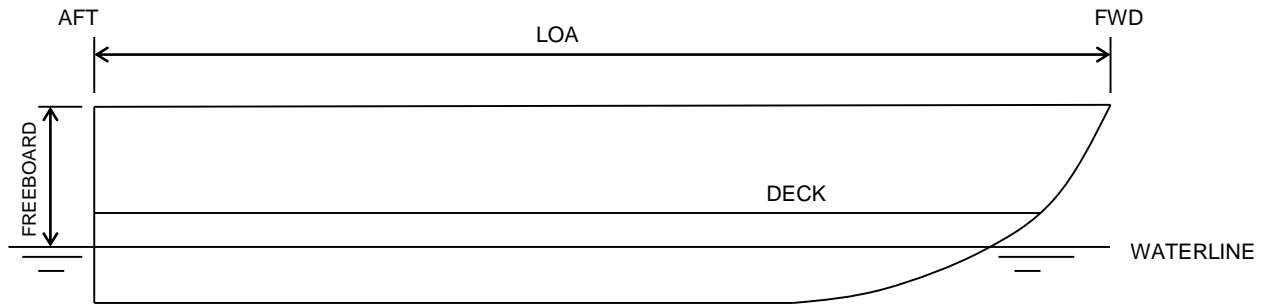

Note: Freeboard on a decked “wet-deck vessel is the distance from the waterline to the lowest point of water ingress on a vessel (excluding scuppers) and may also be in way of the transom. Freeboard on a decked conventional vessel is from the waterline to the deck.

**2. Record of Initial Freeboard Measurements**

Measure the vessel freeboards (forward, midships & aft) with the vessel in the following condition:

- Engine and other solid weights on board.
- Fuel and other tanks 75% to 100% full.
- Crew and Passengers not on board.

Description	Freeboard [mm]		
	Port	Stbd	Mean
Forward			
Midships			
Aft			

Remarks: \_\_\_\_\_

**3. Record of Loaded Freeboard Measurements**

Measure the vessel freeboards (forward, midships & aft) with the vessel in the fully loaded condition; viz,

- Crew and Passengers on board (in addition to loads in paragraph 2).

Description	Freeboard [mm]		
	Port	Stbd	Mean
Forward			
Midships			
Aft			

Remarks: \_\_\_\_\_

**4. Criteria:** Freeboard at lowest point (in fully loaded condition) may not be less than:

$$F_{MIN} = \left( 762 - \left( \frac{18.3 - LOA}{12.2} \right) \times 381 \right)$$

$$= \text{_____ [mm]}$$

PASS	FAIL
------	------

Remarks: \_\_\_\_\_  
 \_\_\_\_\_  
 \_\_\_\_\_

**5. Intact Stability – Maximum Heeling Moment**

Step 1 - With the vessel in an upright fully loaded condition, measure the freeboards at midships, Port and Stbd (Transfer midship values from paragraph 2)

Step 2 - Transfer the weights or “passengers” in a controlled manner from Port to Stbd so that 75% of the passengers are on the Stbd Side and 25% remain on the Port Side. Measure and record the freeboards at midships and calculate the heel angle.

**Criteria:** Heel angle less than 7 degrees and deck edge immersion may not occur.  
 Heel Angle;  $\Theta = \tan^{-1} (\text{Freeboard Port} - \text{Freeboard Stbd})/B_F$

Step 3 - Transfer the remainder of the weights/“passengers” to the Stbd Side so that the maximum practical heeling moment to Stbd is created. Measure and record the freeboards at midships.

**Criteria:** Capsizing moment may not be introduced nor may a downflood point(s) be reached.

Step 4 - Restore the weights/“passenger” to the initial condition (as in Step 1).

Step 5 - Repeat Step 2 but transferring the weights/”passengers” from Stbd to Port.

Step 6 - Repeat Step 2 but transferring the weights/”passengers” from Stbd to Port.

Step 7 - Restore the weights/“passenger” to the initial condition (as in Step 1).

Step	Description	Freeboard Measurement at Midships [mm]		Heel Angle [degrees]	Deck Edge Immersion? Yes/No	Downflood Point reached? Yes/No
		Port	Stbd			
1	Initial Condition					
2	75/25 Heeling Moment (Stbd)					
3	Maximum Heeling Moment					
4	Restore to Initial Condition					
5	75/25 Heeling Moment (Port)					
6	Maximum Heeling Moment					
7	Restore to Initial Condition					

Description of weights/”passenger” shifted to achieve heeling moments with remarks (if any):

\_\_\_\_\_

\_\_\_\_\_

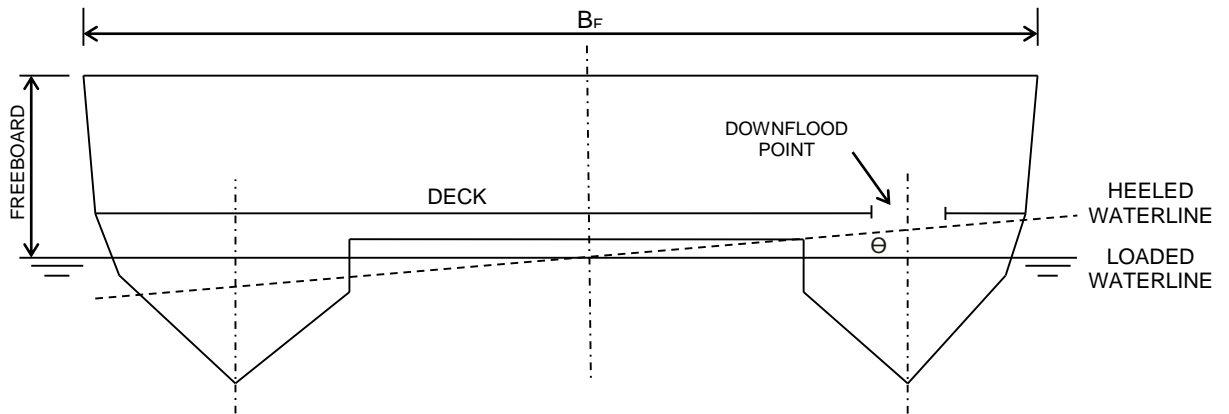

**Downflooding point -** An opening through which progressive flooding of a hull will take place which is not able to be closed watertight. On decked vessels (see sketch above), downflood points are openings in the hull which lead to below deck space(s). On undecked vessels, the downflood point is the lowest point on the hull which will lead to water ingress into the vessel.

**Criteria:** a. For 75/25 applied heeling moment; resultant heel angle less than 7 degrees and no deck edge immersion.

PASS	FAIL
------	------

b. For maximum applied heeling moment; capsizing moment not introduced and no downflood point reached.

PASS	FAIL
------	------

Remarks:

\_\_\_\_\_

\_\_\_\_\_

**PART E – INTACT STABILITY (PONTOON VESSELS)**

**NB – ONLY APPLICABLE TO CATEGORY R VESSELS**

**1. Vessel Principal Particulars**

- a. Length Overall; LOA = \_\_\_\_\_ [m]
  - b. Breadth (max); B = \_\_\_\_\_ [m]
  - c. Breadth for measured freeboards at midships; B<sub>F</sub> = \_\_\_\_\_ [m]
- Note: The heel angle (Para 3) is calculated from freeboards measured at this position

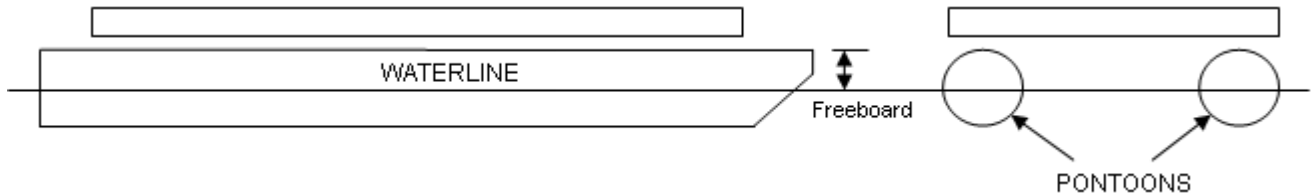

Note: Freeboard is the vertical distance measured from the top of the pontoon to the waterline (Not from the top of the deck).

**2. Record of Initial Freeboard Measurements**

Measure the vessel freeboards (forward, midships & aft) with the vessel in the following condition:

- Engine and other solid weights on board.
- Fuel and other tanks 75% to 100% full.
- Crew and Passengers not on board.

Description	Freeboard [mm]		
	Port	Stbd	Mean
Forward			
Midships			
Aft			

Remarks: \_\_\_\_\_

**3. Record of Loaded Freeboard Measurements**

Measure the vessel freeboards (forward, midships & aft) with the vessel in the fully loaded condition; viz,

- Crew and Passengers on board (in addition to loads in paragraph 2).

Description	Freeboard [mm]		
	Port	Stbd	Mean
Forward			
Midships			
Aft			

Remarks: \_\_\_\_\_

**4. Criteria:** Freeboard at lowest point (in fully loaded condition) may not be less than:

$$F_{MIN} = (762 - \left(\frac{18.3 - LOA}{12.2}\right) \times 381)$$

$$= \text{_____ [mm]}$$

PASS	FAIL
------	------

Remarks: \_\_\_\_\_  
 \_\_\_\_\_  
 \_\_\_\_\_

**5. Intact Stability – Maximum Heeling Moment (Transverse Stability)**

Step 1 - With the vessel in an upright fully loaded condition, measure the freeboards at midships, Port and Stbd (Transfer midship values from paragraph 2)

Step 2 - Transfer the weights or “passengers” in a controlled manner from Port to Stbd so that 75% of the passengers are on the Stbd Side and 25% remain on the Port Side. Measure and record the freeboards at midships and calculate the heel angle.

Criteria: Heel angle must be less than 7 degrees.

$$\text{Heel Angle; } \theta = \tan^{-1} (\text{Freeboard Port} - \text{Freeboard Stbd})/B_F$$

Step 3 - Transfer the remainder of the weights/“passengers” to the Stbd Side so that the maximum practical heeling moment to Stbd is created. Measure and record the freeboards at midships.

Criteria: A maximum of 50% of the reserve of buoyancy of the Stbd pontoon may become submerged nor may a downflood point(s) be reached.

Step 4 - Restore the weights/“passenger” to the initial condition (as in Step 1).

Step 5 - Repeat Step 2 but transferring the weights/”passengers” from Stbd to Port.

Step 6 - Repeat Step 2 but transferring the weights/”passengers” from Stbd to Port.

Step 7 - Restore the weights/“passenger” to the initial condition (as in Step 1).

Step	Description	Freeboard Measurement at Midships				Heel Angle [degrees]	Downflood Point reached? Yes/No	A2 > (A1 - A2) ? A1 = A <sub>LOADED</sub> A2 = A <sub>LOADED &amp; HEELED</sub> Yes/No
		Freeboard [mm]		Area's [m <sup>2</sup> ]				
		Port	Stbd	Port	Stbd			
1	Initial Condition			A1				
2	75/25 Heeling Moment (Stbd)							
3	Maximum Heeling Moment				A2			
4	Restore to Initial Condition							
5	75/25 Heeling Moment (Port)							
6	Maximum Heeling Moment			A2				
7	Restore to Initial Condition							

Description of weights/”passenger” shifted to achieve heeling moments with remarks (if any):

\_\_\_\_\_

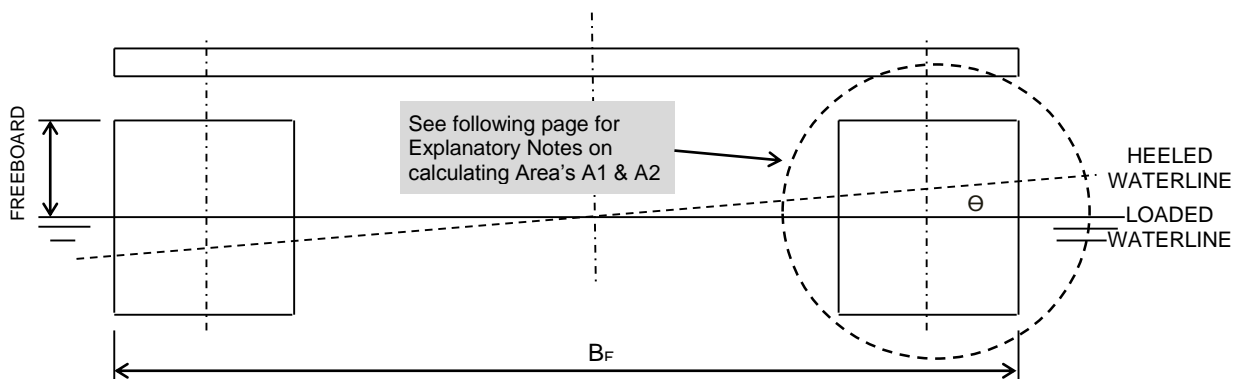

Downflooding point - An opening through which progressive flooding of a pontoon will take place which is not able to be closed weathertight.

Criteria: a. For 75/25 applied heeling moment;  
Resultant heel angle less than 7 degrees.

PASS	FAIL
------	------

b. For maximum applied heeling moment;  
A2 > (A1 - A2) and no downflood point reached.

PASS	FAIL
------	------

Remarks: \_\_\_\_\_  
\_\_\_\_\_

**6. Explanatory Notes – Calculation of Pontoon Area's**

**a. Rectangular pontoons**

Step 1 – Measure Pontoon Breadth; B

B = Pontoon Breadth

Step 2 – With Vessel in “Loaded Condition”

Measure Freeboard; F<sub>1</sub>

F<sub>1</sub> = Loaded Freeboard

Step 3 - Calculate Area A<sub>1</sub>

A<sub>1</sub> = B x F<sub>1</sub>

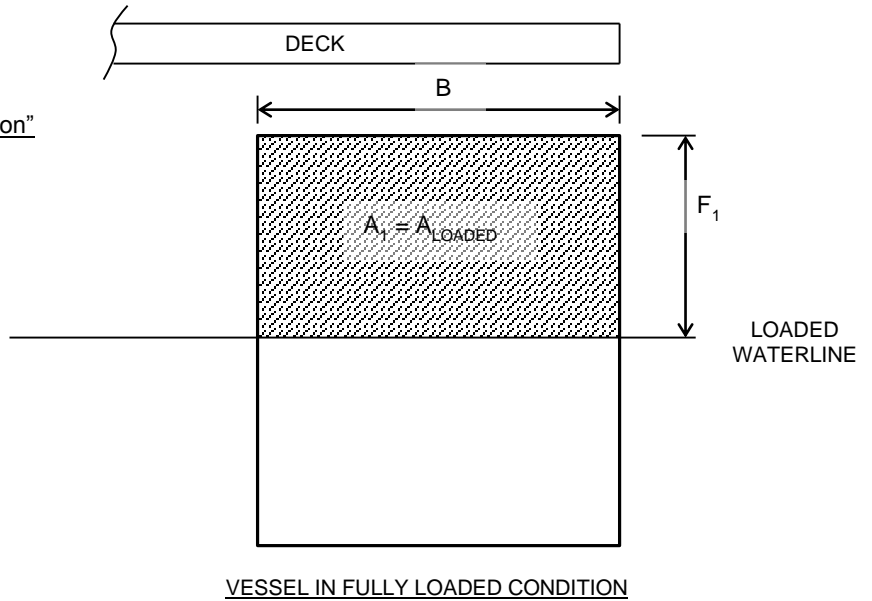

Step 4 – With Vessel in “Loaded & Max Heeled Condition” Measure Freeboard; F<sub>2</sub>

F<sub>2</sub> = Loaded & Max. Heeled Freeboard

Step 5 - Calculate Area A<sub>2</sub>

A<sub>2</sub> = B x F<sub>2</sub>

NB - For calculation purposes an assumption is made that the “Maximum Heel Loaded Waterline” and “Loaded Waterline” are parallel to each other.

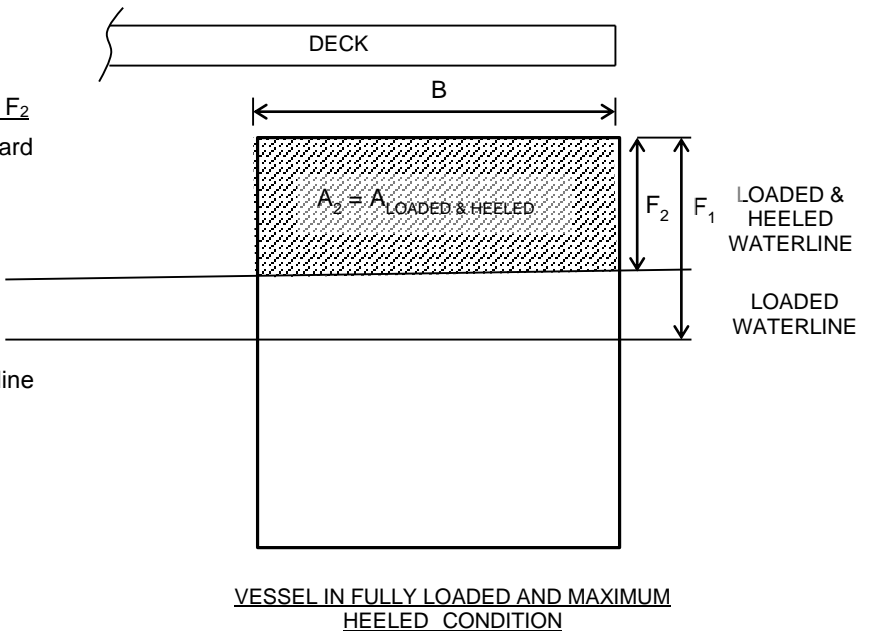

Step 8 – Criteria Check

Confirm A<sub>2</sub> > A<sub>1</sub> – A<sub>2</sub>

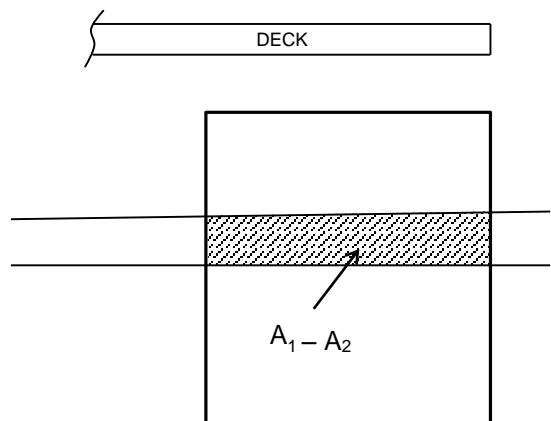
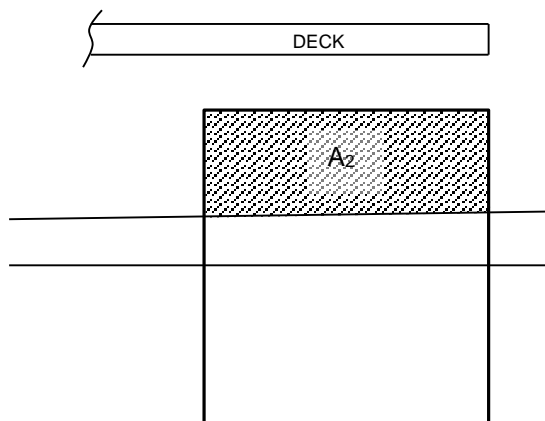

**b. Circular Pontoons**

Step 1 – Measure Pontoon Diameter; D

D = Pontoon Diameter  
 r = Pontoon Radius; D/2

Step 2 – With Vessel in “Loaded Condition”

Measure Freeboard; F<sub>1</sub>

F<sub>1</sub> = Loaded Freeboard  
 h = F<sub>1</sub> - r

Step 3 - Calculate Area (A<sub>1</sub> + A<sub>2</sub>)

$$\phi = \sin^{-1}(h/r)$$

$$\Theta = 180^\circ - 2\phi \quad (\text{if waterline above half-depth of pontoon})$$

$$\Theta = 180^\circ + 2\phi \quad (\text{if waterline below half-depth of pontoon})$$

$$(A_1 + A_\Delta) = \left(\frac{\Theta}{360}\right) \times \pi r^2$$

Step 4 – Calculate Area A<sub>2</sub>

$$A_\Delta = r \cos \phi \times h$$

Step 5 – Calculate Area A<sub>1</sub>

$$A_1 = (A_1 + A_\Delta) - A_\Delta$$

$$= A_{\text{LOADED}}$$

Step 5 – With Vessel in “Loaded & Max. Heeled Condition” Measure Freeboard; F<sub>2</sub>

F<sub>2</sub> = Loaded & Max Heeled Freeboard  
 h = F<sub>2</sub> - r

Step 6 – Repeat Steps 3 & 4

NB - For calculation purposes an assumption is made that the “Maximum Heel Loaded Waterline” and “Loaded Waterline” are parallel to each other.

Step 7 – Calculate Area A<sub>1</sub>

$$A_2 = (A_2 + A_\Delta) - A_\Delta$$

$$= A_{\text{LOADED \& HEELED}}$$

Step 8 – Criteria Check

$$A_{\text{LOADED \& HEELED}} > A_{\text{LOADED}} - A_{\text{LOADED \& HEELED}}?$$

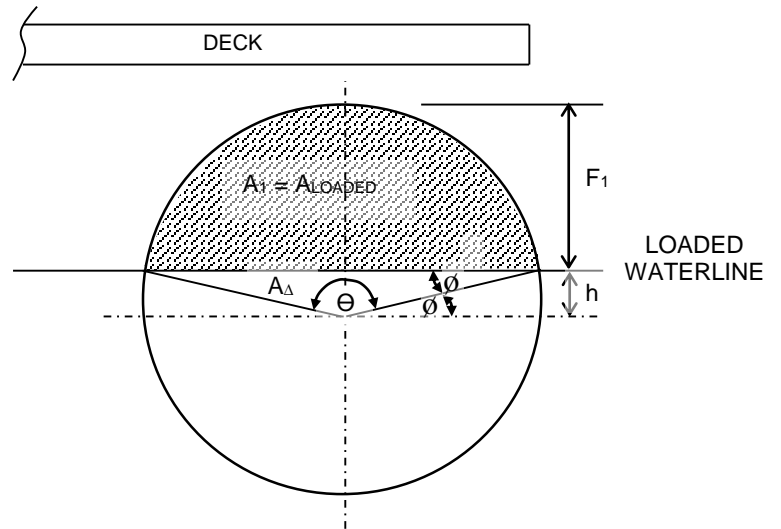

VESSEL IN FULLY LOADED AND CONDITION

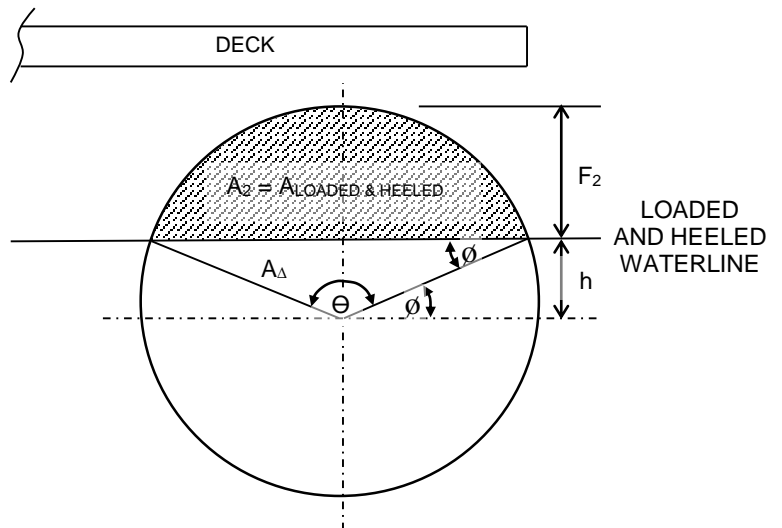

VESSEL IN FULLY LOADED AND MAXIMUM HEELED CONDITION

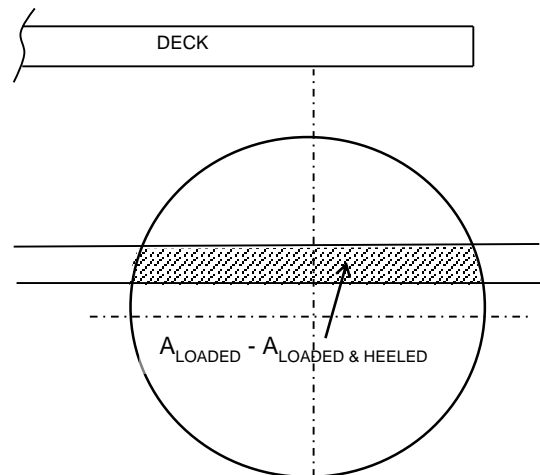
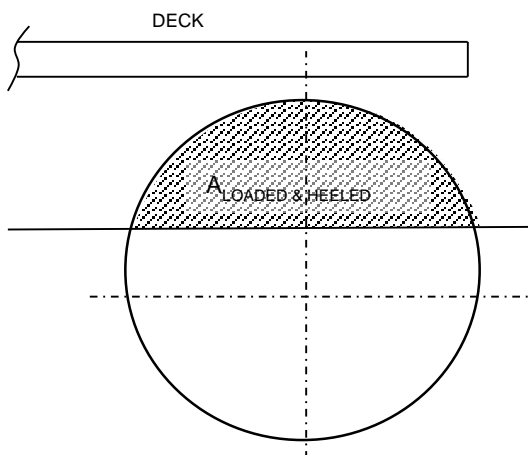

**c. Conventional Hull Shapes**

Step 1 – Measure Pontoon Breadth:  $B_1$  &  $B_2$

$B_1 =$  Pontoon Breadth (Top of Pontoon)  
 $B_2 =$  Pontoon Breadth (Waterline)  
 $= B_1 - (2 \times b)$

Step 2 – With Vessel in “Loaded Condition”

Measure Freeboard:  $F_1$

$F_1 =$  Loaded Freeboard

Step 3 - Calculate Area  $A_1$

$A_1 = (B_1 + B_2)/2 \times F_1$

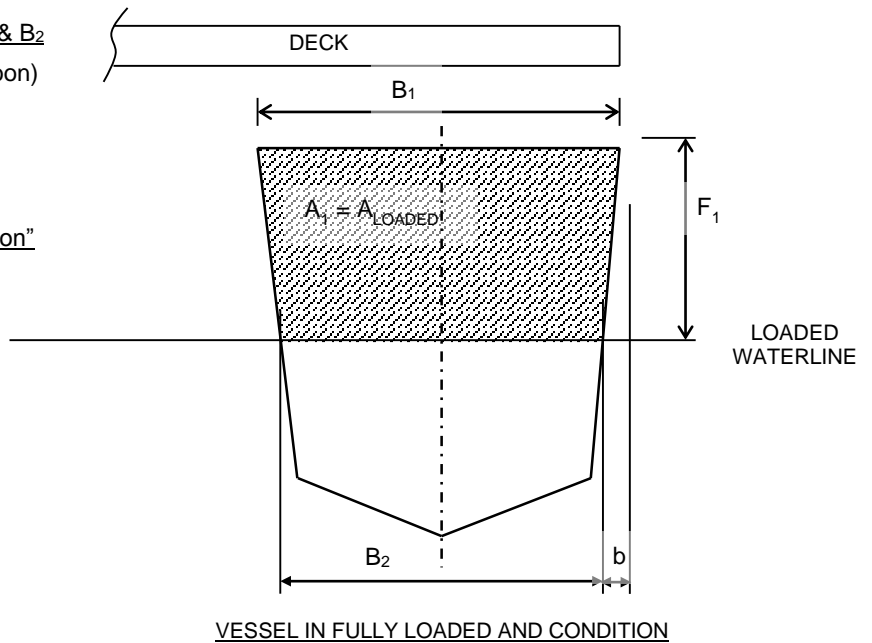

Step 4 – With Vessel in “Loaded & Max Heeled Condition” Measure Freeboard:  $F_2$

$F_2 =$  Loaded & Max. Heeled Freeboard

Step 5 - Calculate Area  $A_2$

$A_2 = (B_1 + B_2)/2 \times F_2$

NB - For calculation purposes an assumption is made that the “Maximum Heel Loaded Waterline and “Loaded Waterline” are parallel to each other.

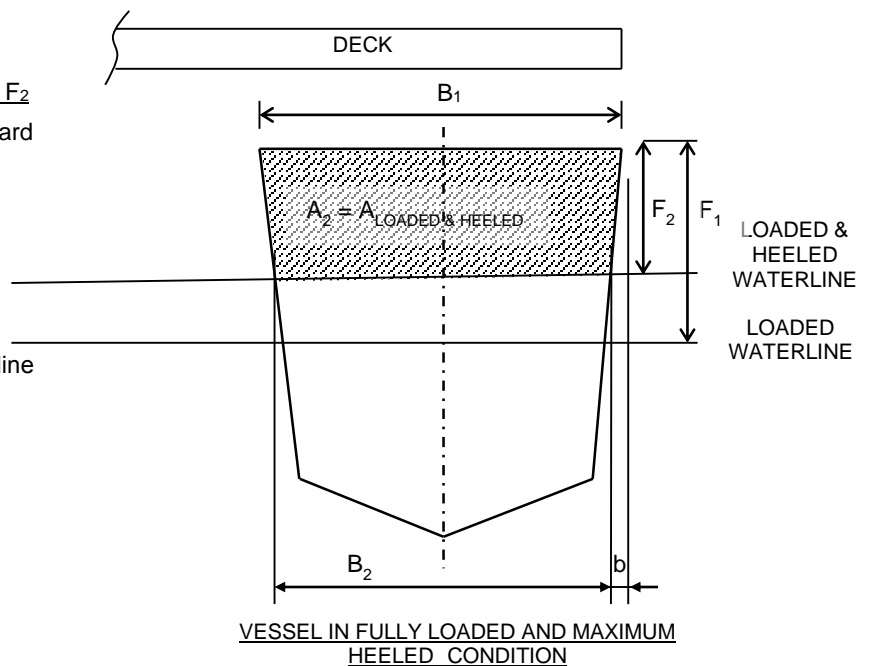

Step 8 – Criteria Check

Confirm  $A_2 > A_1 - A_2$

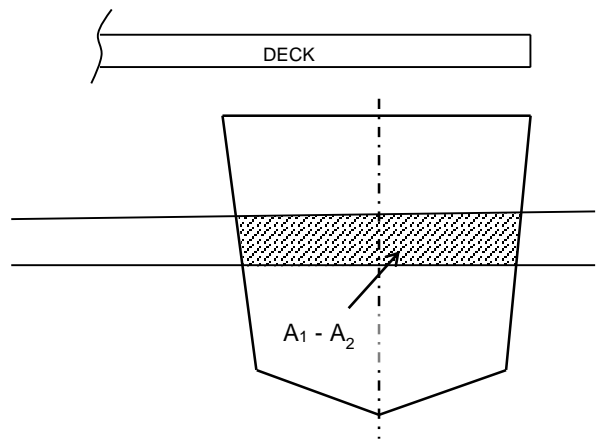
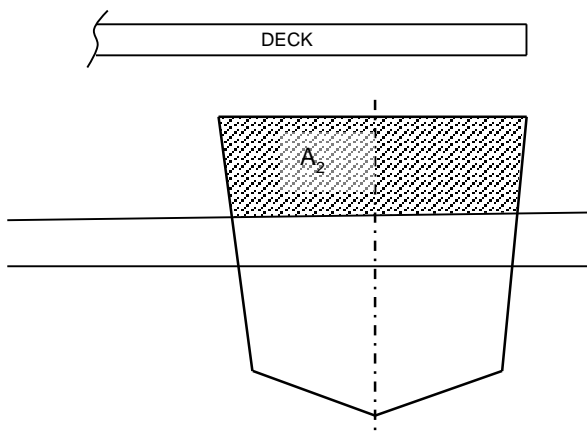

**7. Intact Stability – Maximum Heeling Moment (Longitudinal Stability)**

Step 1 - With the vessel in an upright fully loaded condition, measure the freeboards at midships, Port and Stbd (Transfer midship values from paragraph 2)

Step 2 - Transfer the weights or “passengers” forward in a controlled manner so that the weights or “passengers” are congregated as far forward as is practicable. Measure the trimmed freeboards forward and aft (Port & Stbd)

Step 3 - Restore the weights/“passenger” to the initial condition (as in Step 1).

Step 4 - Repeat Step 2 but transferring the weights/”passengers” aft in a controlled manner so that the weights or “passengers” are congregated as far aft as is practicable. Measure the trimmed freeboards forward and aft (Port & Stbd)

Step 5 - Restore the weights/“passenger” to the initial condition (as in Step 1).

Step	Description	Freeboard Measurements				Forward or Aft section of pontoon(s) submerged? Yes/No
		Freeboard Aft [mm]		Freeboard Fwd [mm]		
		Port	Stbd	Port	Stbd	
1	Initial Condition					
2	Max. Trimming Moment - Fwd					
3	Restore to Initial Condition					
4	Max. Trimming Moment - Aft					
5	Restore to Initial Condition					

Description of weights/”passenger” shifted to achieve trimming moments with remarks (if any):

---



---

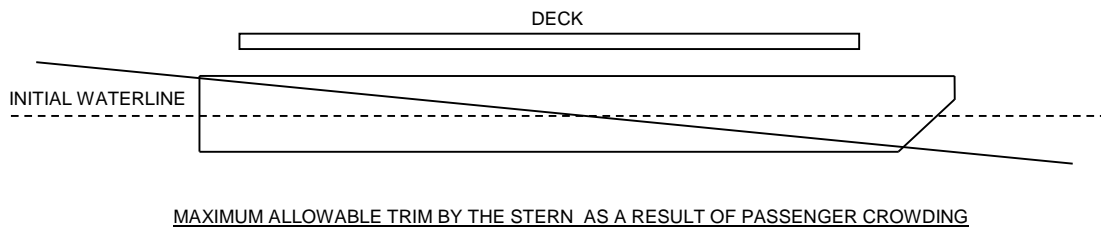
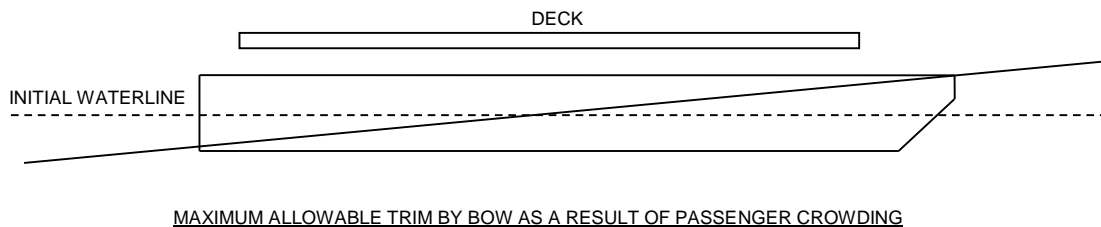

- Criteria:** a. With the vessel trimmed as far forward as is practicable as a result of passenger crowding, the top of the forward pontoon sections may not become submerged.
- b. With the vessel trimmed as far aft as is practicable as a result of passenger crowding, the top of the aft pontoon sections may not become submerged.

PASS	FAIL
------	------

PASS	FAIL
------	------

**PART F - DAMAGED STABILITY**

**IMPORTANT**

1. All passenger vessels are required to remain afloat, with positive transverse stability, when damaged ie. not capsized. All passenger vessels therefore need to demonstrate compliance with this part (practically or theoretically).

a. Vessel method of construction to survive damage (Tick Appropriate Box):

Built-in Buoyancy	
Watertight Sub-division	
Combination of Built-in Buoyancy & Watertight Sub-division	

b. Confirmation of Compliance with Damaged Stability Criteria

Passenger vessels must be able to survive damage as follows:

i. Extent of Damage

Passenger vessels must be able to survive bottom or side damage of length;  $dL = 0.8 + 0.1L$ .

If the compartment lengths are greater than  $0.8 + 0.1L$  then damage of the largest compartment is considered. If the compartment lengths are less than  $0.8 + 0.1L$  then damage of compartments as a result of damage of length;  $dL = 0.8 + 0.1L$  must be considered.

The floodable volume (lost buoyancy) in compartments is therefore dependant on the compartment(s) size and the amount of built-in buoyancy provided in the compartment(s).

ii. Minimum Survival Condition following damage:

Following a damage event with “Extent of Damage” being sustained, the vessel must remain upright with positive transverse stability.

c. Owners have the option of proving compliance theoretically or practically; viz,

i. Theoretical compliance

It must be realised that the ingress of water into a compartment(s) results in changes to the vessel weight and trim and may introduce free surface. Simplified calculations, illustrated in Part F2, may be carried out, however, in the event of doubt and in any case if the water ingress as a result of damage will result in deck edge immersion, is required that a theoretical calculation be carried out by a naval architect and submitted for approval.

ii. Practical Compliance

A practical flooding test of the vessel may be carried out as follows:

Step 1 - The vessel must be initially loaded with all safety and operational equipment on board, including crew and passengers. Fuel and water tanks must be between 75% and 100% full. Crew and passengers must be located as for the vessels normal operation at the start of the test and may not be shifted to improve (or worsen) the condition of the vessel during the practical test.

Step 2 - Determine the “Extent of Damage” for the vessel in accordance with paragraph 1(b)(i) and then progressively flood the vessel, taking care not to create a capsize condition until an equilibrium point is reached where the water level inside the compartment(s) is equal to the outside water level.

Criteria: In the damaged condition, the vessel must remain upright with positive transverse stability.

d. Test Results

i. Vessel Initial Loaded Condition

Description	Freeboard [mm]		
	Port	Stbd	Mean
Forward			
Midships			
Aft			

---



---



---

ii. Vessel Damaged Condition

(a) Description of Simulated Damaged Condition

---



---



---

(b) Sketch of Simulated Damaged Condition

(c) Record of Vessel Freeboards in simulated Damaged Condition

Description	Freeboard [mm]		
	Port	Stbd	Mean
Forward			
Midships			
Aft			

e. Criteria: The vessel must remain upright with positive transverse stability.

PASS	FAIL
------	------

No downflood point may be reached.

Remarks:

---



---



---

**Part F2 – Theoretical Compliance (Use additional pages as required)**

**Part F2a - Pontoon Vessels**

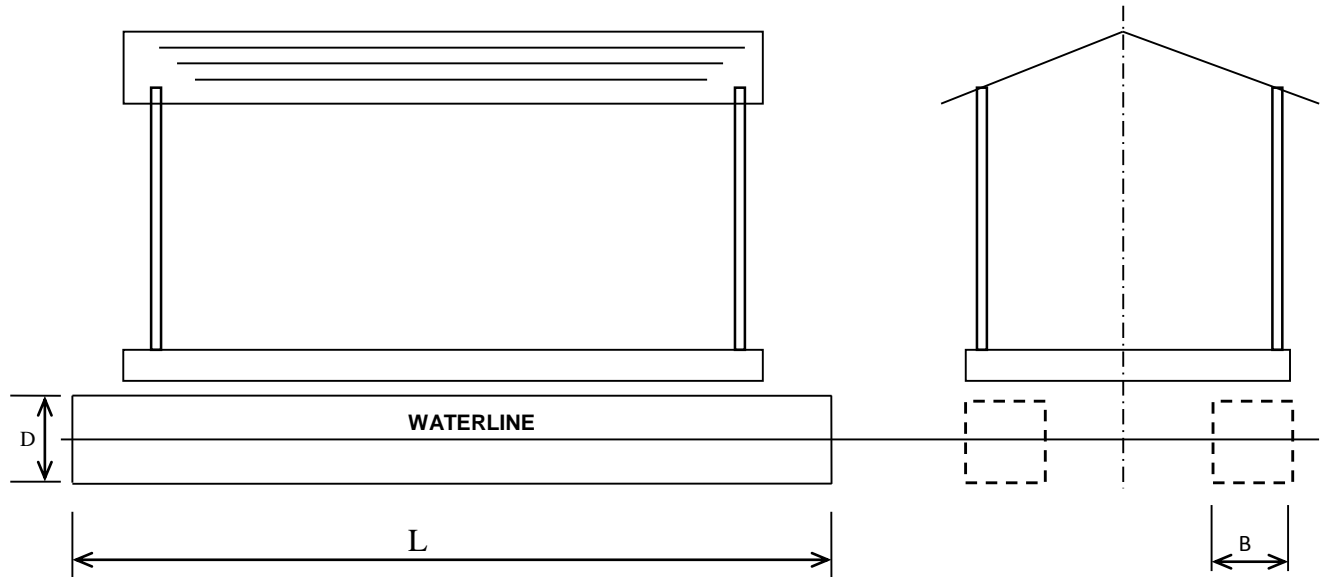

With reference to the above sketch; List the following vessel particulars:

- a. Deck Length \_\_\_\_\_ [m]
- b. Breadth \_\_\_\_\_ [m]
- c. Depth \_\_\_\_\_ [m]

**STEP 1 - CALCULATION OF VESSEL WEIGHT**

Vessel weight = Lightweight + Deadweight. . . . . (1)

The vessel weight may either be obtained by weighing the boat or by Archimedes Principle  
 ie. Weight of Boat = Weight of Water Displaced by Boat

If the weight of the boat is obtained by weighing, complete table 1 below:

Description	Weight [kg]
Weight of Boat (as weighed)	
Less Engine weight(s)	
Less Miscellaneous weights	
<b>Therefore; Lightweight of boat =</b>	

Table 1

If the vessel lightweight is to be calculated from Archimedes Principle:

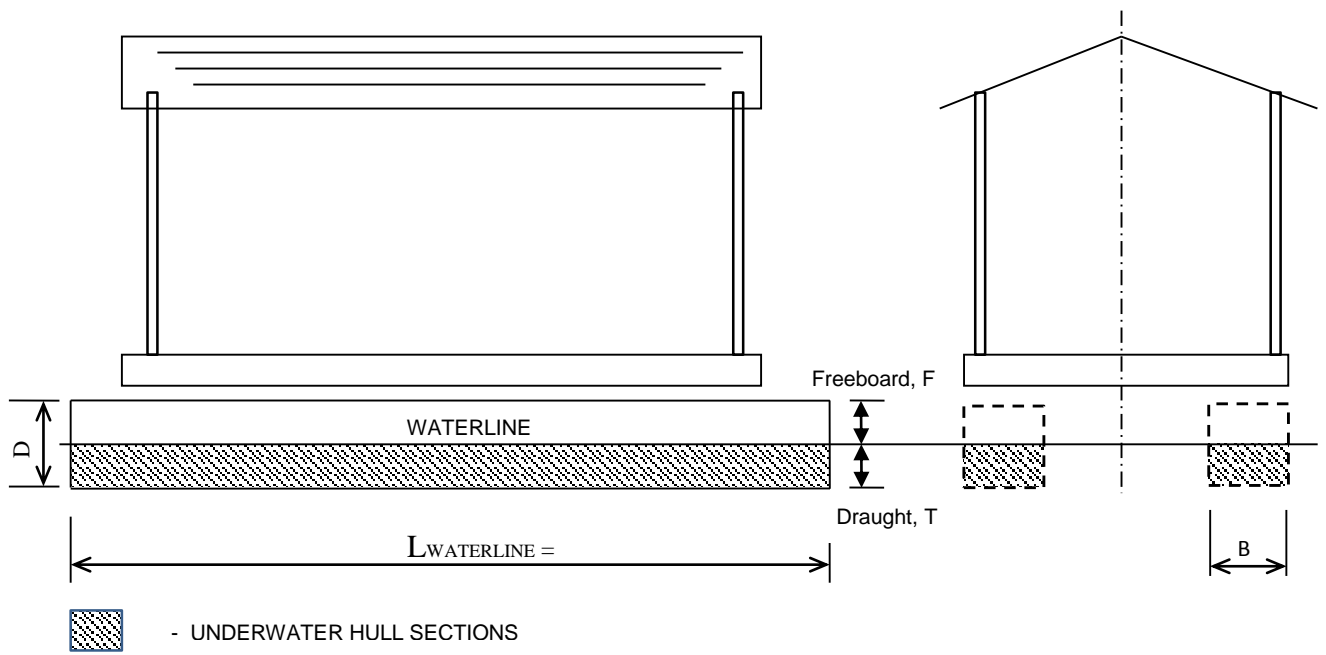

$$M_w = V_w = A_{\text{UNDERWATER HULL SECTIONS}} \times L_{\text{WATERLINE}} \dots (2)$$

Using basic geometry equations calculate the weight of the pontoon vessel using equation (2) in the space below and then complete Table 1.

Determine the total weight of the boat in the loaded condition by completing the following table:

Description	Weight [kg]	Weight [kg]
Lightweight of Boat		
Add Passengers & Crew (82.5 kg per person <sup>0</sup> )		
Add Engine weights		
Add Fuel weight		
Add Safety Equipment weight		
Add weight of passenger & crew effects		
Add Miscellaneous weights		
<b>Therefore; Total Weight of Boat (Worst Load Condition)</b>		

Table 2

## STEP 2 - DETERMINE REQUIRED PONTOON BUOYANCY TO PREVENT CAPSIZE

The total weight of the boat (table 2) is supported by the pontoons which provide buoyancy plus a reserve of buoyancy. In the event of damage, the reserve of buoyancy must be such that the vessel will remain afloat. For a pontoon vessel provided with 2 pontoons, each pontoon must support 50% of the total weight; Therefore,

$$\text{Minimum Pontoon Buoyancy (when damaged)} = 50\% \text{ of Total Weight of Boat}$$

Description	Weight [kg]	Remark
Total Weight of Boat		From Table 2
x50%		or [m <sup>3</sup> ]; SG water ≈ 1.0
Therefore; minimum pontoon buoyancy to avoid capsize; $V_{\text{BUOYANCY REQUIRED}} =$		[m <sup>3</sup> ]

Table 3

**STEP 3 – CALCULATE PONTOON BUOYANCY FOLLOWING DAMAGE**

Extent of Damage =  $0.8 + 0.1 L =$  \_\_\_\_\_ [m]

Sketch the pontoon vessel configuration and resultant flooding as a result of damage = “Extent of Damage”

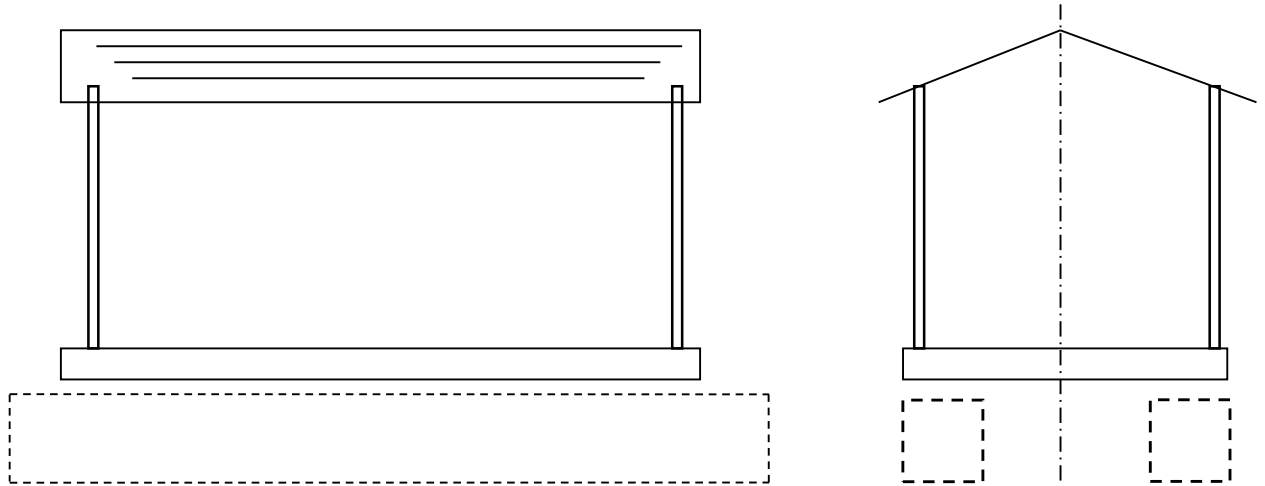

Calculate the Buoyancy in the Damaged Pontoon;  $V_{\text{BUOYANCY DAMAGED}}$

---



---



---



---



---



---



---



---

Therefore:  $V_{\text{BUOYANCY DAMAGED}} =$  \_\_\_\_\_ [m<sup>3</sup>]

**STEP 4 - CONFIRM BUOYANCY IN DAMAGED PONTOON SUFFICIENT TO AVOID CAPSIZE**

$V_{\text{BUOYANCY REQUIRED}} =$  \_\_\_\_\_ [m<sup>3</sup>] From Table 3

$V_{\text{BUOYANCY DAMAGED}} =$  \_\_\_\_\_ [m<sup>3</sup>]

If  $V_{\text{BUOYANCY DAMAGED}} > V_{\text{BUOYANCY REQUIRED}}$  then vessel will remain afloat and not capsize.

REMARKS:

---



---



---

**Part F2 – Theoretical Compliance (Use additional pages as required)**

**Part F2b - Monohulls**

Notes 1. Theoretical calculations may only be carried out by surveyors if the vessel is provided with built-in buoyancy. In the event of the vessel being provided with watertight sub-divisions, the owner must either prove compliance practically or make use of the services of a naval architect to prove theoretical compliance.

2. If the below deck volume is filled with built-in buoyancy with 100% permeability eg. closed cell polyurethane foam and the vessel deck is above the waterline in the fully loaded condition, then it is not necessary to carry out a theoretical damaged stability calculation as no water ingress into the hull will take place in the event of damage.

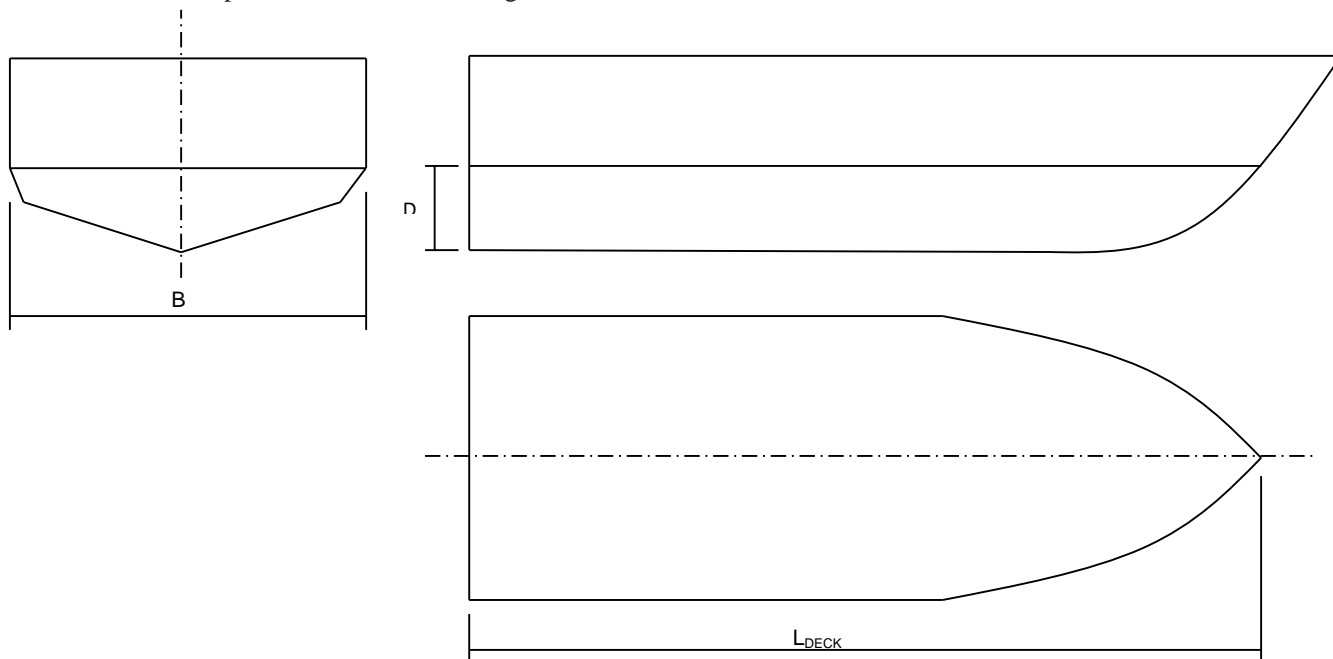

With reference to the above sketch; List the following vessel particulars:

- a. Deck Length \_\_\_\_\_ [m]
- b. Breadth \_\_\_\_\_ [m]
- c. Depth \_\_\_\_\_ [m]

**STEP 1 - CALCULATION OF VESSEL WEIGHT**

Vessel weight = Lightweight + Deadweight. . . . . (1)

The vessel weight may either be obtained by weighing the boat or by Archimedes Principle ie. Weight of Boat = Weight of Water Displaced by Boat

If the weight of the boat is obtained by weighing, complete table 1 below:

Description	Weight [kg]
Weight of Boat (as weighed)	
Less Engine weight(s)	
Less Miscellaneous weights	
<b>Therefore; Lightweight of boat =</b>	

Table 1



Determine the total weight of the boat in the loaded condition by completing the following table:

Description	Weight [kg]	Weight [kg]
Lightweight of Boat		
Add Passengers & Crew (82.5 kg per person)		
Add Engine weights		
Add Fuel weight		
Add Safety Equipment weight		
Add weight of passenger & crew effects		
Add Miscellaneous weights		
<b>Therefore; Total Weight of Boat (Worst Load Condition)</b>		

Table 2

**STEP 2 - DETERMINE THE AMOUNT OF INSTALLED BUILT-IN BUOYANCY**

The boat is required to remain afloat when fully flooded with positive transverse stability in its worst envisaged load condition. Built-in Buoyancy for the Total Weight of the Boat as determined in Table 2 must therefore be provided below the deck.

Draw a sketch of the built-in buoyancy provided in the vessel below clearly indicating the location(s) and type of built-in buoyancy installed:

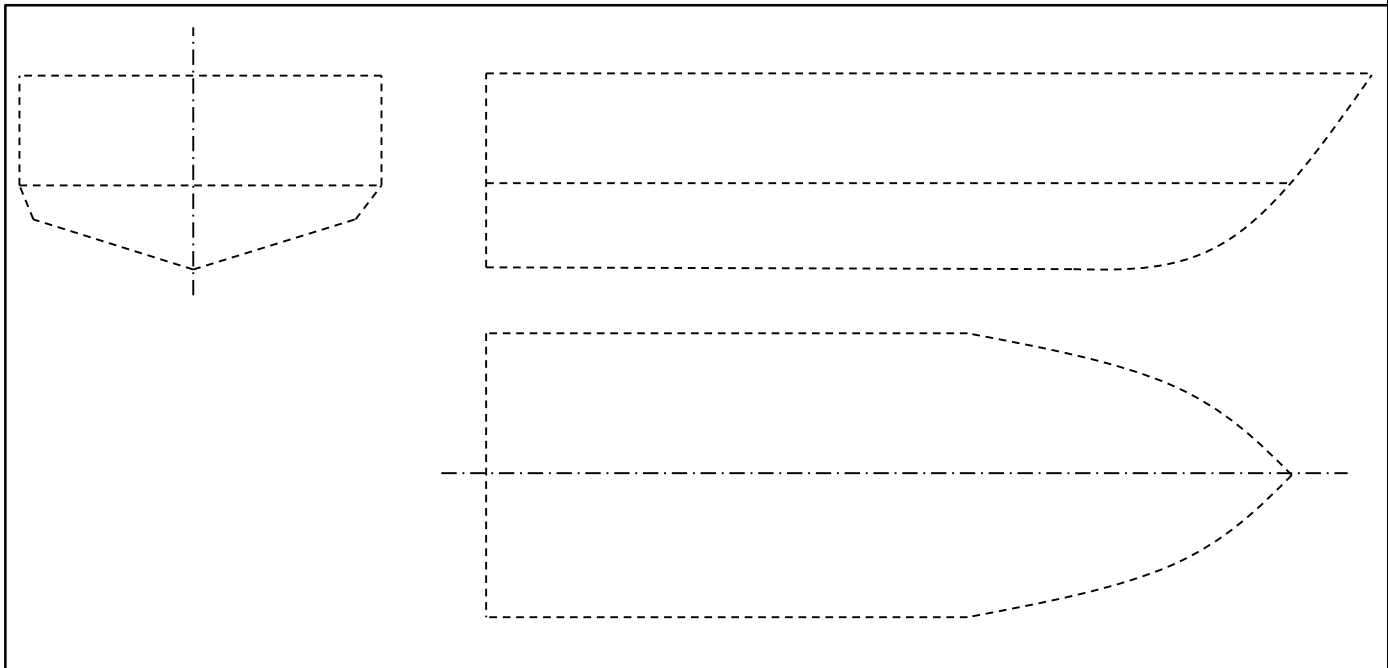

Remarks:

---



---



---



---



---



**Part F2 – Theoretical Compliance (Use additional pages as required)**

**Part F2c - Multihulls**

Notes 1. Theoretical calculations may only be carried out by surveyors if the vessel is provided with built-in buoyancy. In the event of the vessel being provided with watertight sub-divisions, the owner must either prove compliance practically or make use of the services of a naval architect to prove theoretical compliance.

2. If the below deck volume is filled with built-in buoyancy with 100% permeability eg. closed cell polyurethane foam and the vessel deck is above the waterline in the fully loaded condition, then it is not necessary to carry out a theoretical damaged stability calculation as no water ingress into the hull will take place in the event of damage.

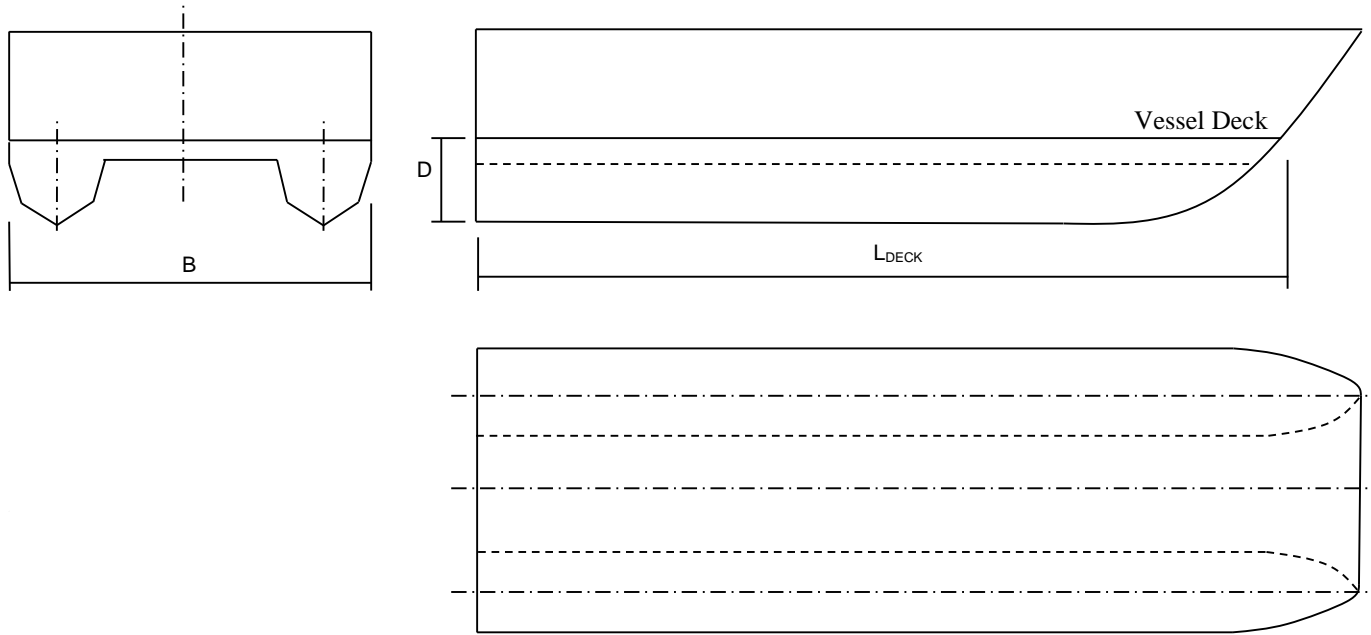

With reference to the above sketch; List the following vessel particulars:

- a. Deck Length \_\_\_\_\_ [m]
- b. Breadth \_\_\_\_\_ [m]
- c. Depth \_\_\_\_\_ [m]

**STEP 1 - CALCULATION OF VESSEL WEIGHT**

Vessel weight = Lightweight + Deadweight. . . . . (1)

The vessel weight may either be obtained by weighing the boat or by Archimedes Principle  
ie. Weight of Boat = Weight of Water Displaced by Boat

If the weight of the boat is obtained by weighing, complete table 1 below:

Description	Weight [kg]
Weight of Boat (as weighed)	
Less Engine weight(s)	
Less Miscellaneous weights	
<b>Therefore; Lightweight of boat =</b>	

Table 1



Determine the total weight of the boat in the loaded condition by completing the following table:

Description	Weight [kg]	Weight [kg]
Lightweight of Boat		
Add Passengers & Crew (82.5 kg per person)		
Add Engine weights		
Add Fuel weight		
Add Safety Equipment weight		
Add weight of passenger & crew effects		
Add Miscellaneous weights		
<b>Therefore; Total Weight of Boat (Worst Load Condition)</b>		

Table 2

**STEP 2 - DETERMINE THE AMOUNT OF INSTALLED BUILT-IN BUOYANCY**

The boat is required to remain afloat when fully flooded with positive transverse stability in its worst envisaged load condition. Built-in Buoyancy for the Total Weight of the Boat as determined in Table 2 must therefore be provided below the deck.

Draw a sketch of the built-in buoyancy provided in the vessel below clearly indicating the location(s) and type of built-in buoyancy installed:

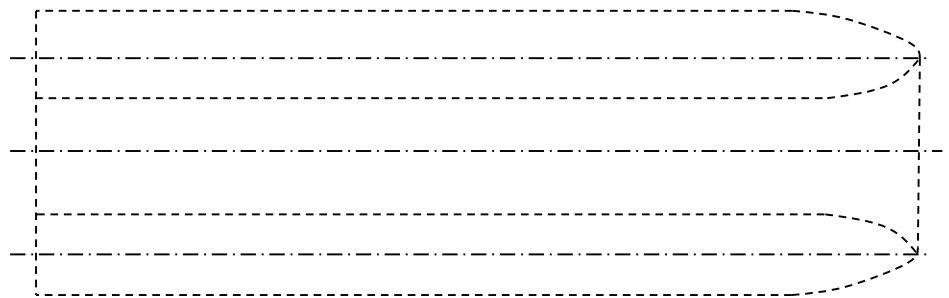
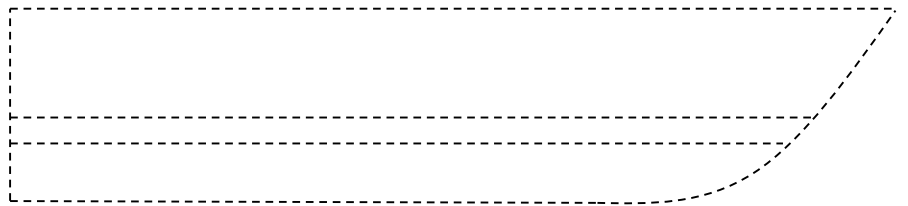
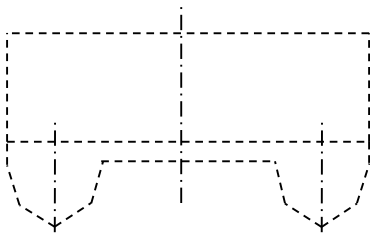

Remarks:

---



---



---



---



---



**PRACTICAL STABILITY TEST**

**RESULTS SUMMARY PAGE**

**A. INTACT STABILITY**

i. Minimum Freeboard

Required: \_\_\_\_\_

Achieved: \_\_\_\_\_

PASS

FAIL

ii. Partial Heeling Moment

Required: \_\_\_\_\_

Achieved: \_\_\_\_\_

PASS

FAIL

iii. Maximum Heeling Moment

Required: \_\_\_\_\_

Achieved: \_\_\_\_\_

PASS

FAIL

**B. DAMAGED STABILITY**

Required: \_\_\_\_\_

Achieved: \_\_\_\_\_

PASS

FAIL

EXEMPTIONS/REMARKS:

\_\_\_\_\_  
\_\_\_\_\_  
\_\_\_\_\_  
\_\_\_\_\_  
\_\_\_\_\_  
\_\_\_\_\_  
\_\_\_\_\_

\_\_\_\_\_  
SURVEYOR NAME & SIGNATURE

\_\_\_\_\_  
DATE

\_\_\_\_\_  
PRINCIPAL OFFICER SIGNATURE

\_\_\_\_\_  
DATE